



Service Data

SD-08-2418

Bendix® AD-IS® and AD-IS® PuraGuard® (Oil Coalescing) Air Dryer and Reservoir Systems

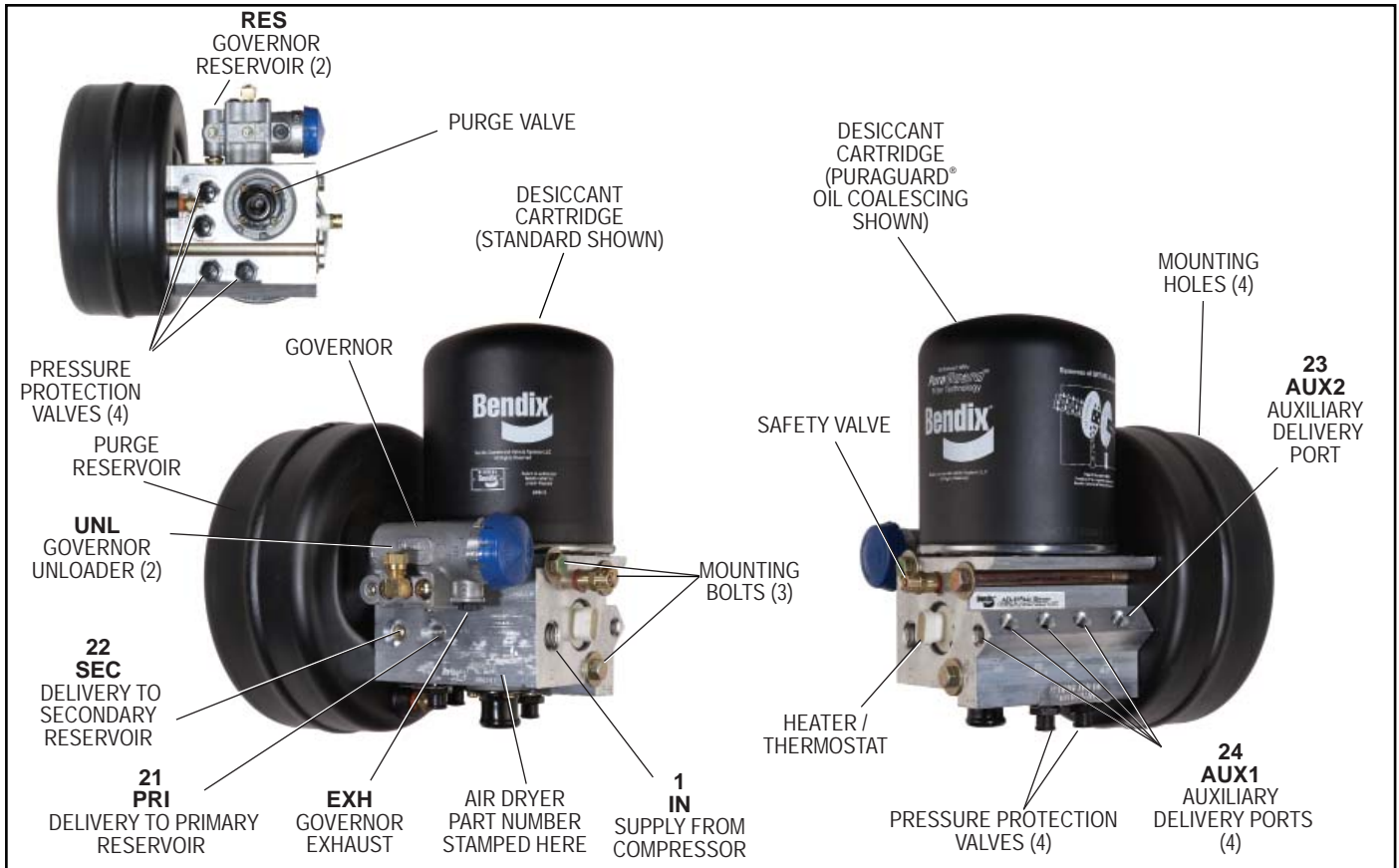

FIGURE 1 - BENDIX® AD-IS® AND AD-IS® PURAGUARD® OIL COALESCING AIR DRYER AND RESERVOIR SYSTEMS

DESCRIPTION

The function of both the Bendix® AD-IS® (*Integrated Solution Air Dryer*) air dryer and reservoir system and the Bendix® AD-IS® PuraGuard® oil coalescing air dryer and reservoir system is to collect and remove air system contaminants in solid, liquid and aerosol form before they enter the brake system and to provide—as a module—heavy vehicles with an integrated vehicle air dryer, purge reservoir, governor and a number of the charging valve components in a module. These components have been designed as an integrated air supply system.

Both air dryer and reservoir systems provide clean, dry air to the components of the brake system which increases the life of the system and reduces maintenance costs. The necessity for daily manual draining of the reservoirs is eliminated.

| Air Connection Port ID | Function/ Connection | QTY |
|------------------------|--|-----|
| 1 IN | Inlet Port (air in) | 1 |
| 21 PRI | Delivery Port Out (to Primary Reservoir) | 1 |
| 22 SEC | Delivery Port out (to Secondary Reservoir) | 1 |
| 24 AUX 1 | Auxiliary Delivery Port (air out) | 4 |
| 23 AUX 2 | Auxiliary Delivery Port (air out) | 1 |
| UNL | Unloader Control Air (D-2A™ Governor) | 2 |
| RES | Common Reservoir Pressure (D-2A™ Governor) | 2 |
| EXH | Governor Exhaust | 1 |

TABLE 1 - PORT DESIGNATIONS

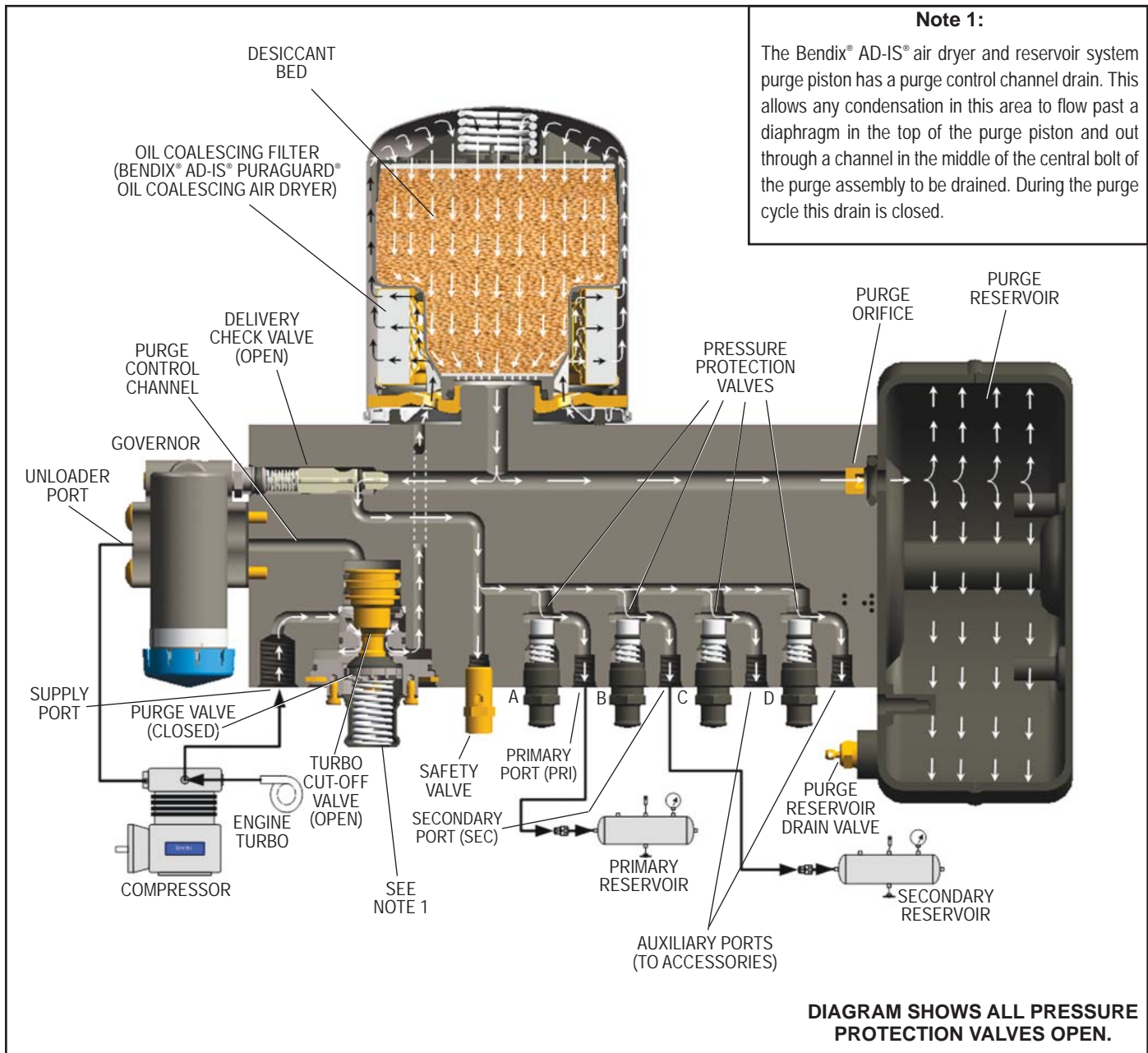

FIGURE 2 - BENDIX® AD-IS® AIR DRYER AND RESERVOIR SYSTEM CHARGE CYCLE

The Bendix® AD-IS® PuraGuard® oil coalescing air dryer has an identical appearance to the standard AD-IS® air dryer, but contains a coalescing media at the inlet of the desiccant bed. The coalescing media provides a higher level of oil removal over the standard AD-IS air dryer. The AD-IS PuraGuard oil coalescing air dryer has all of the same functions as the standard AD-IS air dryer and is used in applications where lower oil concentration levels are required.

Important! When servicing, note that standard AD-IS air dryers or air dryer cartridges may be serviced with PuraGuard oil coalescing air dryers or cartridges, however, PuraGuard oil coalescing air dryers or cartridges must only be serviced with like replacements.

Note: Unless otherwise stated in this manual, AD-IS air dryer and reservoir systems refers to both the standard and PuraGuard oil coalescing air dryer and reservoir systems.

The function of the pressure protection valves is to protect each reservoir from a pressure loss in the other reservoir or a pressure loss in an air accessory. Each of the pressure protection valves in the AD-IS air dryer and reservoir systems may have different pressure settings. These are factory set and must not be changed or adjusted.

The air dryer and reservoir system consists of a “spin on” desiccant cartridge secured to a base assembly. The base assembly contains a delivery check valve assembly,

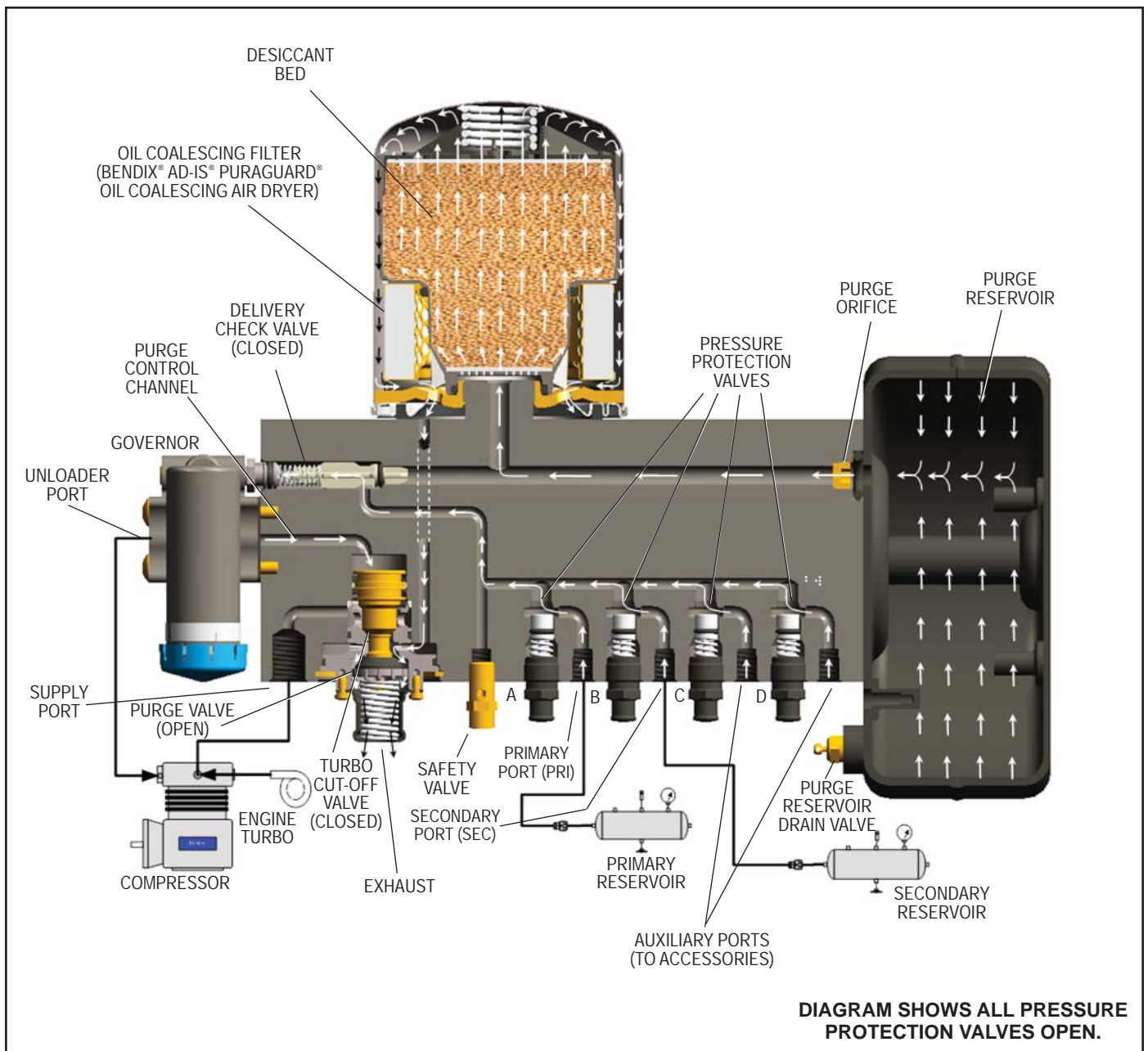

FIGURE 3 - BENDIX® AD-IS® AIR DRYER AND RESERVOIR SYSTEM PURGE CYCLE

safety valve, heater and thermostat assembly, pressure protection valves, threaded air connections and the purge valve assembly.

The removable purge valve assembly incorporates the purge valve mechanism and a turbocharger cut-off feature that is designed to prevent loss of engine “turbo” boost pressure during the purge cycle of the Bendix® AD-IS® air dryer and reservoir system. For ease of maintenance, all replaceable assemblies can be serviced without removal of the air dryer and reservoir system from its mounting on the vehicle. Refer to *Preventive Maintenance* section.

BENDIX® AD-IS® AIR DRYER AND RESERVOIR SYSTEM OPERATION: GENERAL
(Refer to Figure 2.)

The AD-IS air dryer and reservoir systems are designed to receive compressed air from the vehicle air compressor, clean and dry the air, deliver air to the vehicle’s primary reservoir, secondary reservoir and accessories, and control the compressor/dryer charge cycle.

AIR DRYER AND RESERVOIR SYSTEM

OPERATION: GENERAL

The Bendix® AD-IS® air dryer and reservoir system alternates between two modes or “cycles” during operation: the Charge Cycle and the Purge Cycle. The following describes these “cycles” of operation.

CHARGE CYCLE (Refer to Figure 2.)

When the compressor is running loaded (compressing air), compressed air flows through the compressor discharge line to the inlet (1/IN) port of the air dryer body. The compressed air often includes contaminants such as oil, oil vapor, water, and water vapor.

Traveling through the discharge line and into the air dryer, the temperature of the compressed air falls, causing some of the contaminants to condense and drop to the bottom of the air dryer and purge valve assembly. These contaminants are ready to be expelled at the next purge cycle. The air then flows into the desiccant cartridge, where it flows through an oil separator—or coalescing filter if equipped with a PuraGuard® oil coalescing cartridge—which removes water in liquid form as well as liquid oil and solid contaminants.

Air then flows into the desiccant drying bed and becomes progressively more dry as water vapor adheres to the desiccant material in a process known as adsorption.

Dry air exits the desiccant cartridge, through the center of the base assembly, then flows to the delivery check valve and through an orifice and into the purge reservoir. The delivery check valve opens, supplying air to the pressure protection valves (A) through (D) simultaneously, the safety valve, and also to the reservoir port of the attached governor. The purge reservoir fills, storing air that will be used to regenerate the desiccant during the purge cycle. This air is available to supply downstream components during the charge mode.

When the air pressure reaches approximately 106 psi, the four pressure protection valves will open and air will be supplied to the primary reservoir, secondary reservoir, and accessories. If the pressure protection valves are preset to different values the valves will open—in order of lowest setting to highest setting—when charging a flat system.

The air dryer and purge reservoir will remain in the charge cycle until the air brake system pressure builds to the governor cut-out setting of approximately 130 psi.

PURGE CYCLE (Refer to Figure 3.)

When air brake system pressure reaches the cut-out setting of the governor, the governor unloads the compressor activating the purge cycle of the air dryer and reservoir.

The governor unloads the compressor by allowing air pressure to fill the line leading to the compressor unloader mechanism. This suspends the delivery of compressed air to the AD-IS® air dryer and reservoir system.

Similarly, the governor also supplies air pressure to the air dryer. The pressure also moves the air dryer purge piston down, opening the purge valve to atmosphere and closing off the compressor air supply to the turbo cut-off valve (covered in the Turbo Cut-off Feature section of this piece). Water and contaminants captured are expelled immediately when the purge valve opens. In addition, air—which was flowing through the desiccant cartridge—changes direction and begins to flow toward the open purge valve. Contaminants collected by the air dryer are removed by air flowing from the purge reservoir through the desiccant drying bed to the open purge valve.

The initial purge and desiccant cartridge decompression lasts only a few seconds, evidenced by an audible burst of air at the air dryer exhaust.

The actual regeneration of the desiccant drying bed begins as dry air from the purge reservoir flows through the purge orifice into the desiccant bed. Pressurized air from the purge reservoir expands after passing through the purge orifice; its pressure lowers and its volume increases. The flow of dry air through the drying bed regenerates the desiccant material by removing any water vapor adhering to it. Approximately 30 seconds are required for the entire contents of the purge reservoir of an AD-IS air dryer and reservoir system to flow through the desiccant drying bed.

The delivery check valve assembly prevents air pressure in the brake system from returning to the air dryer during the purge cycle. After the purge cycle is complete, the air dryer and reservoir system is ready for the next charge cycle to begin.

TURBO CUT-OFF FEATURE (Refer to Figure 3.)

The primary function of the turbo cut-off valve is to prevent loss of engine turbocharger air pressure through the AD-IS air dryer when the dryer is in the purge mode.

At the onset of the purge cycle, the downward travel of the purge piston is stopped when the turbo cut-off valve (the tapered portion of purge piston) contacts its mating metal seat in the purge valve housing. With the turbo cut-off valve seated (in the closed position), air in the compressor discharge line—as well as the AD-IS air dryer inlet port—cannot enter the air dryer. By completing these actions, the turbo cut-off effectively maintains turbo charger boost pressure to the engine.

PREVENTIVE MAINTENANCE

Important: Review the warranty policy before performing any intrusive maintenance procedures. An extended warranty may be voided if intrusive maintenance is performed during this period. Purge valve maintenance is permissible during the warranty period only when using a genuine Bendix® purge valve kit.

Because no two vehicles operate under identical conditions, maintenance and maintenance intervals will vary. Experience is a valuable guide in determining the best maintenance interval for any one particular operation.

Every 900 operating hours, or 25,000 miles, or three (3) months:

1. Check for moisture in the air brake system by opening reservoir drain valves and checking for the presence of water. If moisture is present, the desiccant cartridge may require replacement; however, the following conditions can also cause water accumulation and should be considered before replacing the desiccant:

- A. An outside air source has been used to charge the system. This air did not pass through the drying bed.
- B. Air usage is exceptionally high and not normal for a highway vehicle.

This may be due to accessory air demands or some unusual air requirement that does not allow the compressor to load and unload (compressing and non-compressing cycle) in a normal fashion. Check for high air system leakage. If the vehicle vocation has changed, it may be necessary to upgrade the compressor size. Refer to Bendix Specification BW-100-A/Appendix D, to determine if any changes are necessary. Specification BW-100-A is available from the Bendix TechTeam at 1-800-247-2725 or www.bendix.com.

- C. The location of the air dryer and reservoir system is too close to the air compressor. Refer to Bendix Specification BW-110-A/Appendix B, for discharge line lengths.
- D. In areas where more than a 30 degree range of temperature occurs in one day, small amounts of water can temporarily accumulate in the air brake system due to condensation. Under these conditions, the presence of small amounts of moisture is normal.

For Bendix® AD-IS® PuraGuard® oil coalescing air dryers only - every 3,600 operating hours, or 100,000 miles, or 12 months:

Oil removal requirements for air brake quality vary by vehicle manufacturer. Because vehicle vocation



FIGURE 4 - HEATER AND THERMOSTAT CONNECTOR

and maintenance can influence when the Bendix® AD-IS® PuraGuard® oil coalescing air dryer cartridge requires replacement, each fleet should modify their replacement schedule based on experience. The change out interval will be extended if the compressor passes a low level of particles. The interval will be reduced if excessive carbon particles are delivered to the dryer inlet. Higher compressor build up times at idle, as well as water or oil in downstream reservoirs indicate an AD-IS PuraGuard oil coalescing air dryer desiccant cartridge may need to be replaced.

Note: A small amount of oil in the system is normal and should not be considered as a reason to replace the desiccant cartridge. Some oil at the dryer exhaust is also normal.

2. Visually check for physical damage, such as chaffed or broken air and electrical lines, and broken or missing parts.
3. Check the AD-IS® air dryer and purge reservoir bolts for tightness. See Figure 1. Re-torque the three air dryer bolts to 360–420 in-lbs and the four purge reservoir bolts to 300–360 in-lbs.
4. Perform the Operation & Leakage Tests listed in this publication.

WARNING!

This air dryer is intended to remove moisture and other contaminants normally found in the air brake system. Do not inject alcohol, anti-freeze, or other de-icing substances into—or upstream of—the air dryer and reservoir system. Alcohol is removed by the dryer, but reduces the effectiveness of the device to dry air. Use of these or other substances can damage the air dryer and may void the warranty.

OPERATION & LEAKAGE TESTS (REFER TO THE TROUBLESHOOTING CHART IN THIS MANUAL)

For additional information see video BW2237.

1. Check all lines and fittings leading to and from the air dryer and reservoir system for leakage and integrity. Repair any leaks found.
2. Build up system pressure to governor cut-out and note that the Bendix® AD-IS® air dryer purges with an audible escape of air. Watch the system pressure and note the pressure fall-off for a ten minute period. If pressure drop exceeds—
 - a) for a single vehicle: 1 psi/minute from either service reservoir; or
 - b) for tractor trailer: 3 psi/minute from either service reservoir—inspect the vehicle air systems for leak sources and repair them. Refer to the Symptoms 1 and 4 in the Troubleshooting Chart.
3. **Caution: Be sure to wear safety glasses in case of a purge blast.** Check for excessive leakage around the purge valve with the compressor in the charge mode (compressing air). Apply a soap solution to the purge valve exhaust port and observe that leakage does not exceed a 1" bubble in one second. If any leakage exceeds the maximum specified, refer to Symptom 4 in the Troubleshooting Chart.
4. Build up system pressure to governor cut-out and note that the AD-IS air dryer purges with an audible burst of air, followed immediately by approximately 30 seconds of air flowing out of the purge valve. "Fan" the service brakes to reduce system air pressure to governor cut-in. Note that the system once again builds to full pressure and is followed by a purge. If the system does not follow this pattern, refer to Symptoms 5 and 6 in the Troubleshooting Chart .
5. Check the operation of the end cover heater and thermostat assembly during cold weather operation as follows:

A. Electric Power to the Dryer (Refer to Figure 4.)

With the ignition or engine kill switch in the RUN position, check for voltage to the heater and thermostat assembly using a voltmeter or test light. Unplug the electrical connector at the air dryer and reservoir system and place the test leads on each of the connections of the female connector on the vehicle power lead. If there is no voltage, look for a blown fuse, broken wires, or corrosion in the vehicle wiring harness. Check to see if a good ground path exists.

B. Thermostat and Heater Operation

Note: These tests are not possible except in cold weather operation.

Turn off the ignition switch and cool the thermostat

and heater assembly to below 40° Fahrenheit. Using an ohmmeter, check the resistance between the electrical pins in the air dryer and reservoir system connector half. The resistance should be 1.5 to 3.0 ohms for the 12 volt heater assembly, and 6.0 to 9.0 ohms for the 24 volt heater assembly.

Warm the thermostat and heater assembly to approximately 90° Fahrenheit and again check the resistance. The resistance should exceed 1000 ohms. If the resistance values obtained are within the stated limits, the thermostat and heater assembly is operating properly. If the resistance values obtained are outside the stated limits, replace the heater and thermostat assembly.

6. Pressure Protection Valves. Observe the pressure gauges of the vehicle as system pressure builds from zero. The primary or secondary gauge should rise until it reaches approximately 106 psi (± 6 psi), then level off (or a momentary slight fall) as the next pressure protection valve opens—supplying its reservoir. When that pressure gauge passes through approximately 106

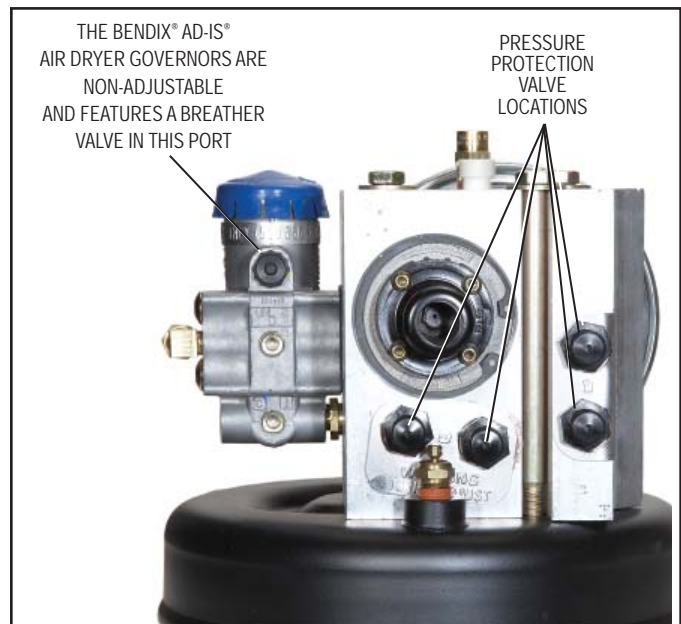

FIGURE 5 - PRESSURE PROTECTION VALVE LOCATIONS

WARNING:

DO NOT ATTEMPT TO ADJUST OR SERVICE THE PRESSURE PROTECTION VALVES. INCORRECT PRESSURE PROTECTION VALVE SETTINGS CAN RESULT IN AUTOMATIC APPLICATION OF VEHICLE SPRING BRAKES WITHOUT PRIOR WARNING.

psi (± 6 psi) there should be an associated leveling off (or momentary slight fall) of pressure as the third and fourth pressure protection valves open. Then the primary and secondary gauges should increase together until they reach their full pressure of approximately 130 psi (± 5 psi).

If the Bendix® AD-IS® air dryer and reservoir system does not perform within the pressure ranges as described above, recheck using gauges known to be accurate. If the readings remain outside of the ranges outlined, replace the AD-IS air dryer and reservoir system. NOTE: There are no kits available for the servicing of the pressure protection valves. Warning: Do not attempt to adjust or service the pressure protection valves—incorrect pressure protection valve settings can result in automatic application of the vehicle spring brakes without prior warning (in the event one of the supply circuits experiences rapid pressure loss).

GENERAL

When rebuilding or replacing components of the air dryer and reservoir, use only genuine Bendix® brand replacement parts. For ease in servicing, the AD-IS air dryer and reservoir have been designed so that maintenance kits can be installed without removing the air dryer and reservoir from the vehicle. **CAUTION:** Always depressurize the air dryer and purge reservoir—and all other reservoirs on the vehicle—to 0 psi before servicing the air dryer.

If—after completing the routine operation and leakage tests—it has been determined that one or more components of the air dryer requires replacement or maintenance, refer to the Maintenance Kit listing shown in this manual or the Bendix® Quick Reference Catalog for the appropriate kit(s). The Quick Reference catalog (BW1114) can be ordered and viewed on line at www.bendix.com.

NOTE: Kits are not available for the servicing of the pressure protection valves (See Figure 5). Do not attempt to adjust or service the pressure protection valves - these are not service items.

TESTING THE BENDIX® AD-IS® AIR DRYER AND RESERVOIR SYSTEM

Before placing the vehicle into service, perform the following tests:

1. Close all reservoir drain valves.
2. Build up system pressure to governor cut-out and note that the Bendix® AD-IS® air dryer purges (with an audible burst of air), followed immediately by approximately 30 seconds of air flowing out of the purge valve.
3. “Fan” the service brakes to reduce system air pressure to governor cut-in. Note that the system once again builds to full pressure and is followed by a purge at the air dryer exhaust.

| Maintenance Kits | |
|---|-----------|
| Kit Description | Piece No. |
| Delivery Check Valve Replacement Kit | 5004052 |
| Desiccant Cartridge Replacement Kit (Standard) | 5008414 |
| Desiccant Cartridge Replacement Kit - Bendix® AD-IS® PuraGuard® air dryer (can be used to replace the standard cartridge) | 5008414PG |
| Drain Valve | 5004961N |
| Governor and Check Valve Replacement Kit | 5004049 |
| Governor Gasket | 5007834 |
| Heater & Thermostat Replacement (12 volt) | 109495 |
| Heater & Thermostat Replacement (24 volt) | 109496 |
| Bendix® PuraGuard® Oil Coalescing Desiccant Cartridge Service New Kit | K020366 |
| Mounting Bolt Kit | 5009233 |
| Protective Boots (for pressure protection valves) | 5005163 |
| Safety Valve | 800350 |
| Splash Shield Kit (includes bracket and cover) | 5006698 |
| Splash Shield Cover | 5005266N |
| Silencer Kit | K021189 |
| Wiring Harness & Splice Kit | 109871N |

| Purge Valve Assembly Type | Configuration | Service Kit Pc. No. |
|---|--------------------------------|---------------------|
| Purge Valve Assembly for climate conditions above -40°C (-40°F) | Bendix® AD-IS® Air Dryer | K022105 |
| | AD-IS® EverFlow® Module | K031560 |
| | AD-IS® Discharge Line Unloader | K031562 |
| Arctic Purge Valve Assembly for climate conditions of -40°C to -50°C (-40°F to -58°F) | AD-IS® Air Dryer | K031559 |
| | AD-IS® EverFlow® Module | K031561 |
| | AD-IS® Discharge Line Unloader | K031563 |

4. It is recommended that the total air system be tested for leakage to assure that the AD-IS air dryer and reservoir system will not cycle excessively.

BRAKING SYSTEM PROTECTION

The AD-IS air dryer allows the system to maintain one brake circuit up to about 100 psi even after a pressure loss in the other brake circuit. This allows a vehicle to be moved (in an emergency), but with reduced braking capacity. Compare this to a conventional system, where a loss of pressure in one service tank leaves the vehicle with a limited number of reduced braking capacity applications before the parking brakes automatically apply and stay on.

See Bendix publication BW5057 "Air Brake Handbook."

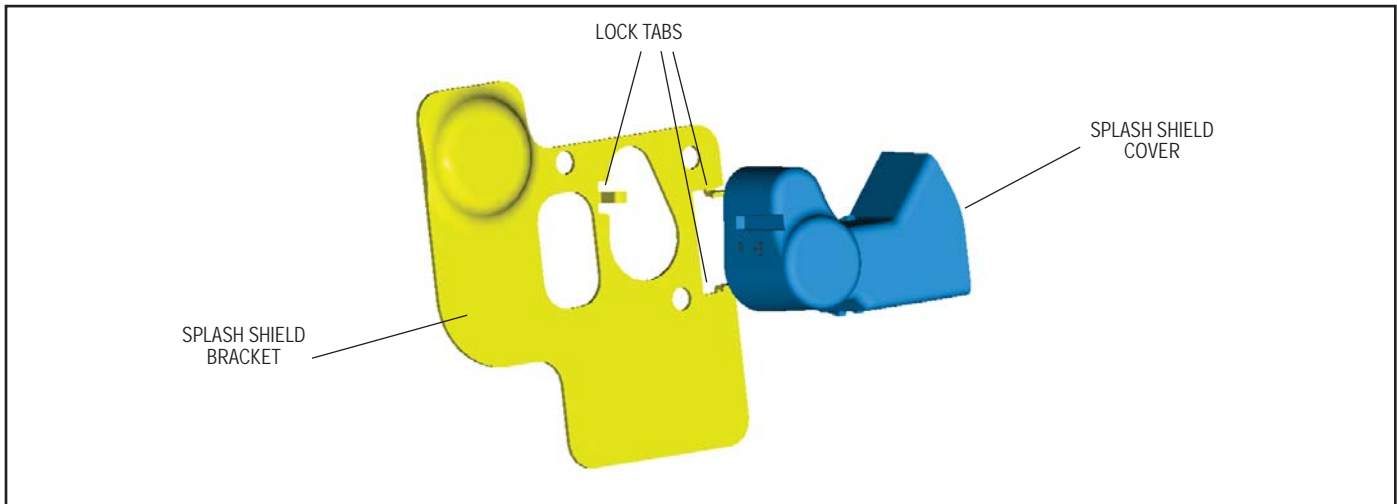

FIGURE 7 - SPLASH SHIELD BRACKET AND COVER - (EXPLODED VIEW)

GENERAL SAFETY GUIDELINES

WARNING! PLEASE READ AND FOLLOW THESE INSTRUCTIONS TO AVOID PERSONAL INJURY OR DEATH:

When working on or around a vehicle, the following general precautions should be observed at all times.

1. Park the vehicle on a level surface, apply the parking brakes, and always block the wheels. Always wear safety glasses.
2. Stop the engine and remove ignition key when working under or around the vehicle. When working in the engine compartment, the engine should be shut off and the ignition key should be removed. Where circumstances require that the engine be in operation, **EXTREME CAUTION** should be used to prevent personal injury resulting from contact with moving, rotating, leaking, heated or electrically charged components.
3. Do not attempt to install, remove, disassemble or assemble a component until you have read and thoroughly understand the recommended procedures. Use only the proper tools and observe all precautions pertaining to use of those tools.
4. If the work is being performed on the vehicle's air brake system, or any auxiliary pressurized air systems, make certain to drain the air pressure from all reservoirs before beginning **ANY** work on the vehicle. If the vehicle is equipped with a Bendix® AD-IS® air dryer system or a dryer reservoir module, be sure to drain the purge reservoir.
5. Following the vehicle manufacturer's recommended procedures, deactivate the electrical system in a manner that safely removes all electrical power from the vehicle.
6. Never exceed manufacturer's recommended pressures.
7. Never connect or disconnect a hose or line containing pressure; it may whip. Never remove a component or plug unless you are certain all system pressure has been depleted.
8. Use only genuine Bendix® brand replacement parts, components and kits. Replacement hardware, tubing, hose, fittings, etc. must be of equivalent size, type and strength as original equipment and be designed specifically for such applications and systems.
9. Components with stripped threads or damaged parts should be replaced rather than repaired. Do not attempt repairs requiring machining or welding unless specifically stated and approved by the vehicle and component manufacturer.
10. Prior to returning the vehicle to service, make certain all components and systems are restored to their proper operating condition.
11. For vehicles with Automatic Traction Control (ATC), the ATC function must be disabled (ATC indicator lamp should be ON) prior to performing any vehicle maintenance where one or more wheels on a drive axle are lifted off the ground and moving.

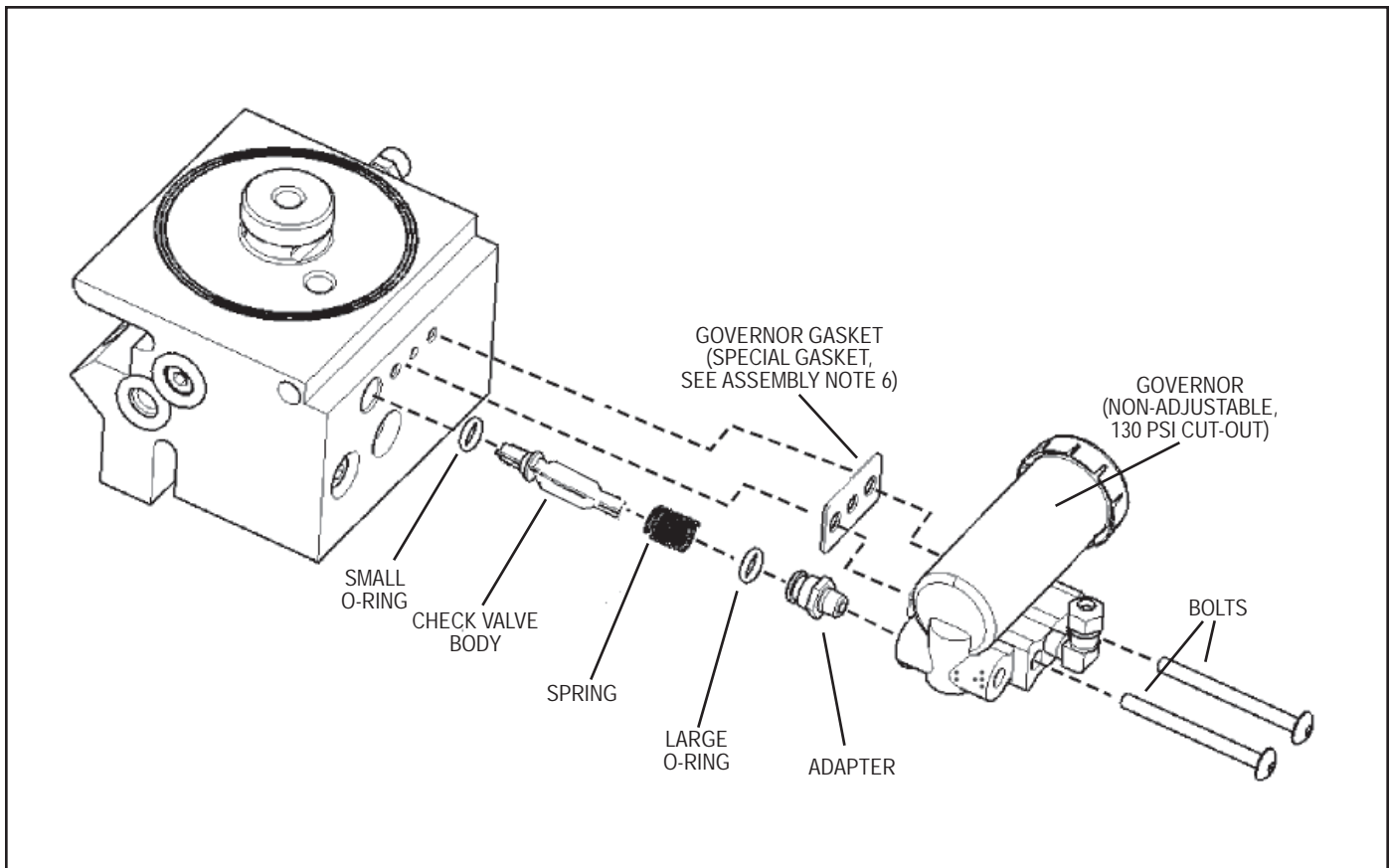

FIGURE 6 - BENDIX® AD-IS® AIR DRYER AND RESERVOIR SYSTEM DELIVERY CHECK VALVE

ROADSIDE INSPECTION

In the event of a roadside inspection the system behavior will be as follows: When the system is charged to governor cut-out and then one reservoir drain valve is opened, initially both reservoir gauges will fall; however, the Bendix® AD-IS® air dryer primary and secondary pressure protection valves will close at pressures above 70 psi, protecting the remaining brake circuit from further loss of pressure.

TEMPORARY AIR DRYER AND RESERVOIR SYSTEM BYPASS

To temporarily bypass the air dryer, follow these procedures:
Adhere to the General Safety Guidelines outlined elsewhere in this document.

Make sure that all residual pressure has been released and the air dryer purge reservoir has been drained to 0 psi, then remove the air supply line from the compressor to the inlet port (1/IN). Remove the safety valve from the Bendix AD-IS air dryer (see Figure 1 for location). Note that a short puff of trapped air may vent from the safety valve port when removing the valve. Install a T-fitting into the port. Using any adapters necessary, reinstall the safety valve in one of the branches of the T-fitting. Using any adapters necessary, install the air supply line into the remaining T-fitting port.

After testing the T-fitting for any air leakage—by using a soap solution after charging to system cut-out pressure (a 1" bubble in 10 seconds is acceptable)—the vehicle may be returned to temporary service.

Note: This is a temporary bypass of the air dryer. Full repair of the unit must be carried out at the earliest opportunity. With the air dryer removed from the system, contaminants will be entering the air brake system: reservoirs will need to be manually drained daily until the repairs are completed. At the end of each working day, park the vehicle and slowly drain pressure through the drain valves—leave open to the atmosphere—for several hours, if possible. When repairs are carried out, be sure to check that all reservoirs (including the air dryer purge reservoir) are emptied of all contaminants.

If, after bypassing the air dryer and reservoir system, the system pressure still does not build, use the following procedure to remove, clean, and reinstall the delivery check valve.

DELIVERY CHECK VALVE CLEANING PROCEDURE

(Note: This is only required if system pressure does not build after temporary bypass is completed.)

Refer to Figure 6 throughout the following procedures. De-pressurize the air brake system following the general safety precautions outlined elsewhere in this document. Also, always de-pressurize the air dryer purge reservoir before servicing the air dryer.

This procedure does not require removal of the Bendix® AD-IS® air dryer and reservoir from the vehicle.

1. Remove the line from the governor and mark for easy re-installation.
2. Remove the bolts attaching the governor to the AD-IS air dryer and reservoir system and retain for re-assembly.
3. Remove the governor from the air dryer. Be aware that a short puff of trapped air may vent when the governor is removed. Retain the governor gasket for re-assembly if a new governor gasket is not available. Remove and retain the o-ring from the adapter.
4. The spring/delivery check valve can now be removed.
5. Remove and retain the o-ring from the check valve body.

CLEANING & INSPECTION

1. Use a suitable solvent to clean all metal parts, and use a cotton swab to clean the bore (Note: Do not use abrasives or tools to clean the bore: any scratches caused may necessitate replacing the Bendix® AD-IS® air dryer and reservoir system.) Superficial external corrosion and/or pitting is acceptable.
2. Clean the o-rings with a clean dry cloth. Do not use solvents.
3. Inspect for physical damage to the bore and the check valve seat. If the bore is damaged (by scratches etc. that would prevent delivery check valve from seating), replace the AD-IS air dryer.
4. Inspect the delivery check valve, o-rings, etc. for wear or damage. Replace, if necessary, using the check valve replacement kit available at any authorized Bendix parts outlets.
5. Inspect all air line fittings for corrosion and replace as necessary.

ASSEMBLY

1. Lubricate the smaller o-ring and check valve body with a heavy duty lithium grease.
2. Install this o-ring on the check valve body by sliding the o-ring over the set of four tapered guide lands. The o-ring groove holds the o-ring in its correct location.
3. At the other end of the check valve body, the spring is installed over the set of four straight guide lands. When the spring has been pushed to the correct location, the check valve body is designed to hold the end of the spring in position: be sure that the spring is not loose before continuing with this installation.
4. Install the assembled check valve body/o-ring/spring in the delivery port so that the o-ring rests on its seat and the free end of the spring is visible.
5. Grease the adapter and the remaining larger o-ring and install it onto the fitting.
6. Position the governor gasket, then insert the governor mounting bolts through the governor and tighten (to 125 in-lbs). **(Note: Do not replace with a standard compressor/governor gasket.)**
7. Re-attach line to the governor.
8. Before placing vehicle back into service, check to see that the system pressure now builds to full operational pressure.

BENDIX® AD-IS® AIR DRYER AND RESERVOIR SYSTEM

TROUBLESHOOTING CHART

| SYMPTOM | CAUSE | REMEDY |
|--|---|--|
| 1. Dryer is constantly "cycling" or purging. | A. Excessive system leakage. | <p>A. Test for excessive system leakage. Allowable leakage observed at dash gauge:</p> <ul style="list-style-type: none"> - Single vehicle - 1 psi/minute. - Tractor trailer - 3 psi/minute. <p>Using soap solution, test vehicle for leakage at fittings, drain valves and system valves and any accessories (i.e. air suspension) connected to the Bendix® AD-IS® air dryer auxiliary ports. If an accessory is suspected to be the cause of leakage, disconnect that accessory from the air dryer, plug the auxiliary port that it was in, and retest the AD-IS air dryer for proper purge cycling. Repair or replace as necessary.</p> |
| | B. Defective delivery check valve. | <p>B. Build system pressure to governor cut-out. Wait 1 minute for completion of purge cycle. Using soap solution at exhaust of purge valve, leakage should not exceed a 1" bubble in less than 5 seconds.</p> <p>If a rapid loss of pressure is found, the following procedure will determine if the delivery check valve is malfunctioning:</p> <p>Build system pressure to governor cut-out and allow a full minute for the normal dryer purge cycle to empty the purge reservoir. Switch off the engine and "fan" the brakes so that the system pressure reaches governor cut-in. The purge valve will return to its closed position. The purge reservoir has a drain valve which is opened by moving the center lever away from its closed position. Open the drain valve and wait 10 seconds to allow any residual purge pressure to be released. Release the lever, closing the drain valve. Carefully remove the air dryer cartridge using a strap wrench and then test for air leaking through the center of the threaded boss by applying a soap solution to the area. Replace the delivery check valve if there is excessive leakage (exceeding a 1" bubble in 5 seconds).</p> <p>Re-grease the seal on the air dryer cartridge before reinstalling. Be sure the drain valve on the purge reservoir is not leaking before restoring vehicle to service.</p> |
| | C. Defective governor. | <p>C. Check governor at both "cut-in" and "cut-out" position for (i) proper pressures and (ii) excessive leakage at fittings and exhaust.</p> |
| | D. Compressor unloader mechanism leaking excessively. | <p>D. Remove air strainer, or fitting, from compressor inlet cavity. With compressor unloaded, check for unloader piston leakage. Slight leakage is permissible.</p> |

BENDIX® AD-IS® AIR DRYER AND RESERVOIR SYSTEM

TROUBLESHOOTING CHART

| SYMPTOM | CAUSE | REMEDY |
|--|--|---|
| 2. Water in vehicle reservoirs | A. Maximum air dryer inlet temperature is exceeded due to improper discharge line length. | A. Check for excessive carbon build up in compressor discharge line. Replace if required. Make certain that discharge line length is at least 6 ft. Increase discharge line length and/or diameter to reduce air dryer inlet temperature. |
| | B. Air system charged from outside air source (outside air not passing through air dryer). | B. If system must have outside air fill provision, outside air should pass through air dryer. |
| | C. Excessive air usage - Air dryer not compatible with vehicle air system requirement (Improper air dryer/vehicle application) | C. Refer to Bendix Advanced Troubleshooting Guide for Air Brake Compressors (BW1971) for proper application of the Bendix® AD-IS® air dryer and reservoir system. An extended purge model (Bendix® AD-IS® EP) is available for many higher air usage vehicles, such as city buses and construction vehicles. If the vehicle is equipped with high air usage accessories such as trailer pump-off systems or central tire inflation, the air for these accessories must by-pass the dryer reservoir system. |
| | D. Desiccant requires replacement. | D. Replace desiccant cartridge assembly. |
| | E. Air by-passes desiccant cartridge assembly. | E. If vehicle uses Holset compressor, inspect feedback check valve for proper installation and operation. |
| | F. Air dryer not purging. | F. Refer to Symptom 6. |
| | G. Purge (air exhaust) time insufficient due to excessive system leakage. | G. Refer to Symptom 1. |
| 3. Safety valve on air dryer "popping off" or exhausting air. | A. Defective AD-IS air dryer and reservoir system delivery check valve. | A. Test to determine if air is passing through check valve. Repair or replace. Refer to Symptom 1, Remedy B. |
| | B. Safety valve setting too low (<150 p.s.i.) | B. Replace safety valve. |
| | C. System pressure too high (>135 p.s.i.) | C. Test with accurate gauge. Replace governor if necessary. |
| | D. Excessive pressure pulsations from compressor. (Typical single cylinder type). | D. Increase volume in discharge line. This can be accomplished by adding a 90 cubic inch (or larger) reservoir between the compressor and the AD-IS® air dryer and reservoir system. |
| 4. Constant exhaust of air at air dryer purge valve exhaust or unable to build system pressure. (Charge mode.) | A. Air dryer purge valve leaking excessively. | A. With compressor loaded, apply soap solution on purge valve exhaust, to test for excessive leakage. Repair or replace purge valve as necessary. Refer to Technical Bulletin TCH-008-040. |
| | B. Purge valve frozen open - faulty heater and thermostat, wiring, blown fuse. | B. Refer to paragraph 5 of the Operation and Leakage Tests for heater and thermostat test. |
| | C. Defective AD-IS air dryer delivery check valve. | C. Refer to Symptom 1, Remedy B. |
| | D. Leaking Turbo Cut-Off valve. | D. Repair or replace purge valve assembly. |
| | E. Defective governor. | E. Check governor at both "cut-in" and "cut-out" position for (i) proper pressures and (ii) excessive leakage at fittings and exhaust. |
| | F. Leaking purge valve control piston seals. | F. Repair or replace purge valve assembly. |

BENDIX® AD-IS® AIR DRYER AND RESERVOIR SYSTEM

TROUBLESHOOTING CHART

| SYMPTOM | CAUSE | REMEDY |
|---|--|--|
| 5. Cannot build system air pressure. | A. Supply pressure to the air dryer is not sufficient. | A. Ensure the supply pressure to the air dryer is greater than 110 psi after the system charges. |
| | B. Kinked or blocked (plugged) discharge line. | B. Check to determine if air passes through discharge line. Check for kinks, bends, excessive carbon deposits, or ice blockage. |
| | C. Excessive bends in discharge line (water collects and freezes). | C. Discharge line should be constantly sloping from compressor to air dryer with as few bends as possible. |
| | D. Pressure protection valve(s) in air dryer will not open. | D. Replace air dryer (pressure protection valves are not serviceable). |
| | E. Refer to Symptom 4. | E. Refer to Symptom 4, Remedy A. |
| | F. Refer to Symptom 7. | F. Refer to Symptom 7, Remedies A and B. |
| 6. Air dryer does not purge or exhaust air. | A. Faulty air dryer purge valve. | A. After determining air reaches purge valve control port by installing a T-fitting with a pressure gauge into the governor unloader port, repair purge valve if necessary. |
| | B. See Causes B, E, and F for Symptom #4. | B. Refer to Symptom 4, Remedies B, E, and F. Also refer to Symptom 1, Remedy B. |
| 7. Desiccant material being expelled from air dryer purge valve exhaust (may look like whitish liquid or paste or small beads.) | A. Faulty dryer cartridge. | A. Replace the Bendix® AD-IS® air dryer cartridge or AD-IS air dryer. |
| | B. Excessive dryer vibration. | B. Check the AD-IS air dryer mounting for looseness or damage. Repair mounting and replace cartridge. |
| 8. Unsatisfactory desiccant life. | A. Excessive system leakage. | A. Refer to Symptom 1, Remedy A. |
| | B. Wrong vehicle application for AD-IS® air dryer. | B. Refer to Symptom 2, Remedy C. |
| | C. Compressor passing excessive oil. | C. Check for proper compressor installation; if symptoms persist, replace compressor. Refer to Bendix Advanced Troubleshooting Guide for Air Brake Compressor (BW1971). |
| 9. "Pinging" noise excessive during compressor loaded cycle. | A. Single cylinder compressor with high pulse cycles. | A. A slight "pinging" sound may be heard during system build up when a single cylinder compressor is used. If this sound is deemed objectionable, it can be reduced substantially by increasing the discharge line volume. This can be accomplished by adding a 90 cubic inch (or larger) reservoir between the compressor and the AD-IS air dryer and reservoir system. |
| 10. The air dryer purge piston cycles rapidly in the compressor unloaded (non-compressing) mode. | A. Compressor fails to "unload". | A. Check air hose from governor to compressor for a missing, kinked or restricted line. Install or repair air hose. Repair or replace compressor unloader. |

