

Bendix® R-7™ Modulating Valve

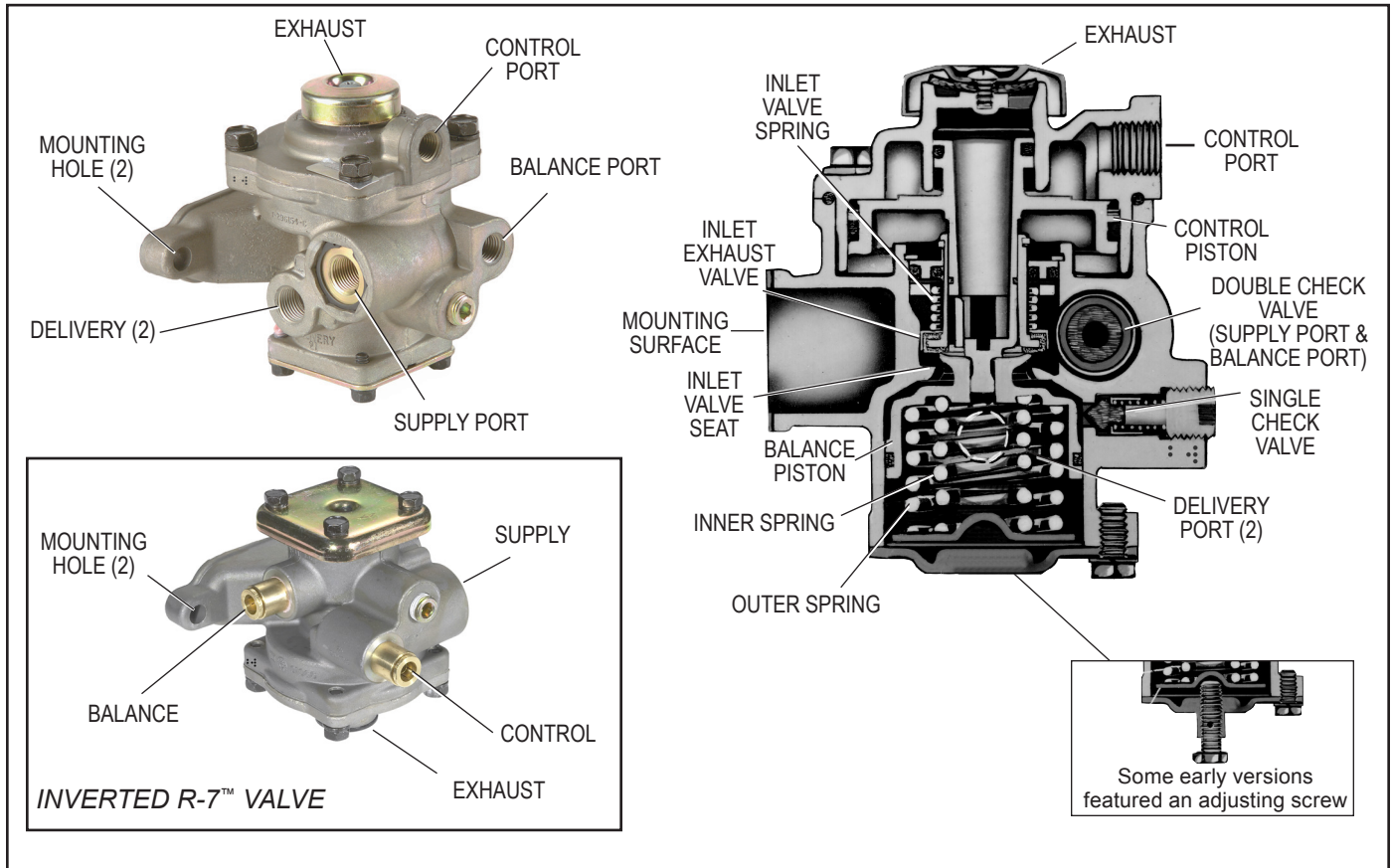

FIGURE 1 - EXTERIOR & SECTIONAL VIEW.

INSET FIGURE 2 - INVERTED VIEW

DESCRIPTION

The Bendix® R-7™ modulating valve is used in conjunction with a dual air brake system and spring brake actuators. Typically the R-7 modulating valve performs four functions:

1. Limits hold-off pressure to the spring brake actuators.
2. Provides a quick release of air pressure from the spring cavity of the spring brake actuator allowing a fast application of the spring brake actuators. The valve delivers air to the park brake quick release valve (or relay) and also releases air in the control line to the quick release valve (or relay).
3. Modulates spring brake actuator application should a failure occur in the primary service brake system.
4. Prevents compounding of service and spring forces.

The valve has one 1/4" control, one 3/8" supply, one 1/4" balance, two 3/8" delivery NPTF ports, and an exhaust port protected by an exhaust diaphragm. The valve incorporates two 13/32" holes for mounting.

Note for model year 2001 and later International® Trucks only: There is an inverted R-7 valve, which appears inverted from the other pictures in this document. A standard R-7 valve and an inverted R-7 valve are not interchangeable. See Figure 2 for a picture of an inverted R-7 valve.

GENERAL SAFETY GUIDELINES



**WARNING! PLEASE READ AND FOLLOW THESE INSTRUCTIONS
TO AVOID PERSONAL INJURY OR DEATH:**



When working on or around a vehicle, the following guidelines should be observed **AT ALL TIMES**:

- ▲ Park the vehicle on a level surface, apply the parking brakes and always block the wheels. Always wear personal protection equipment.
- ▲ Stop the engine and remove the ignition key when working under or around the vehicle. When working in the engine compartment, the engine should be shut off and the ignition key should be removed. Where circumstances require that the engine be in operation, **EXTREME CAUTION** should be used to prevent personal injury resulting from contact with moving, rotating, leaking, heated or electrically-charged components.
- ▲ Do not attempt to install, remove, disassemble or assemble a component until you have read, and thoroughly understand, the recommended procedures. Use only the proper tools and observe all precautions pertaining to use of those tools.
- ▲ If the work is being performed on the vehicle's air brake system, or any auxiliary pressurized air systems, make certain to drain the air pressure from all reservoirs before beginning ANY work on the vehicle. If the vehicle is equipped with a Bendix® AD-IS® air dryer system, a Bendix® DRM™ dryer reservoir module, or a Bendix® AD-9si™ air dryer, be sure to drain the purge reservoir.
- ▲ Following the vehicle manufacturer's recommended procedures, deactivate the electrical system in a manner that safely removes all electrical power from the vehicle.
- ▲ You should consult the vehicle manufacturer's operating and service manuals, and any related literature, in conjunction with the Guidelines above.
- ▲ Never exceed manufacturer's recommended pressures.
- ▲ Never connect or disconnect a hose or line containing pressure; it may whip. Never remove a component or plug unless you are certain all system pressure has been depleted.
- ▲ Use only genuine Bendix® brand replacement parts, components and kits. Replacement hardware, tubing, hose, fittings, etc. must be of equivalent size, type and strength as original equipment and be designed specifically for such applications and systems.
- ▲ Components with stripped threads or damaged parts should be replaced rather than repaired. Do not attempt repairs requiring machining or welding unless specifically stated and approved by the vehicle and component manufacturer.
- ▲ Prior to returning the vehicle to service, make certain all components and systems are restored to their proper operating condition.
- ▲ For vehicles with Automatic Traction Control (ATC), the ATC function must be disabled (ATC indicator lamp should be ON) prior to performing any vehicle maintenance where one or more wheels on a drive axle are lifted off the ground and moving.
- ▲ The power **MUST** be temporarily disconnected from the radar sensor whenever any tests **USING A DYNAMOMETER** are conducted on a Bendix® Wingman® Advanced™-equipped vehicle.

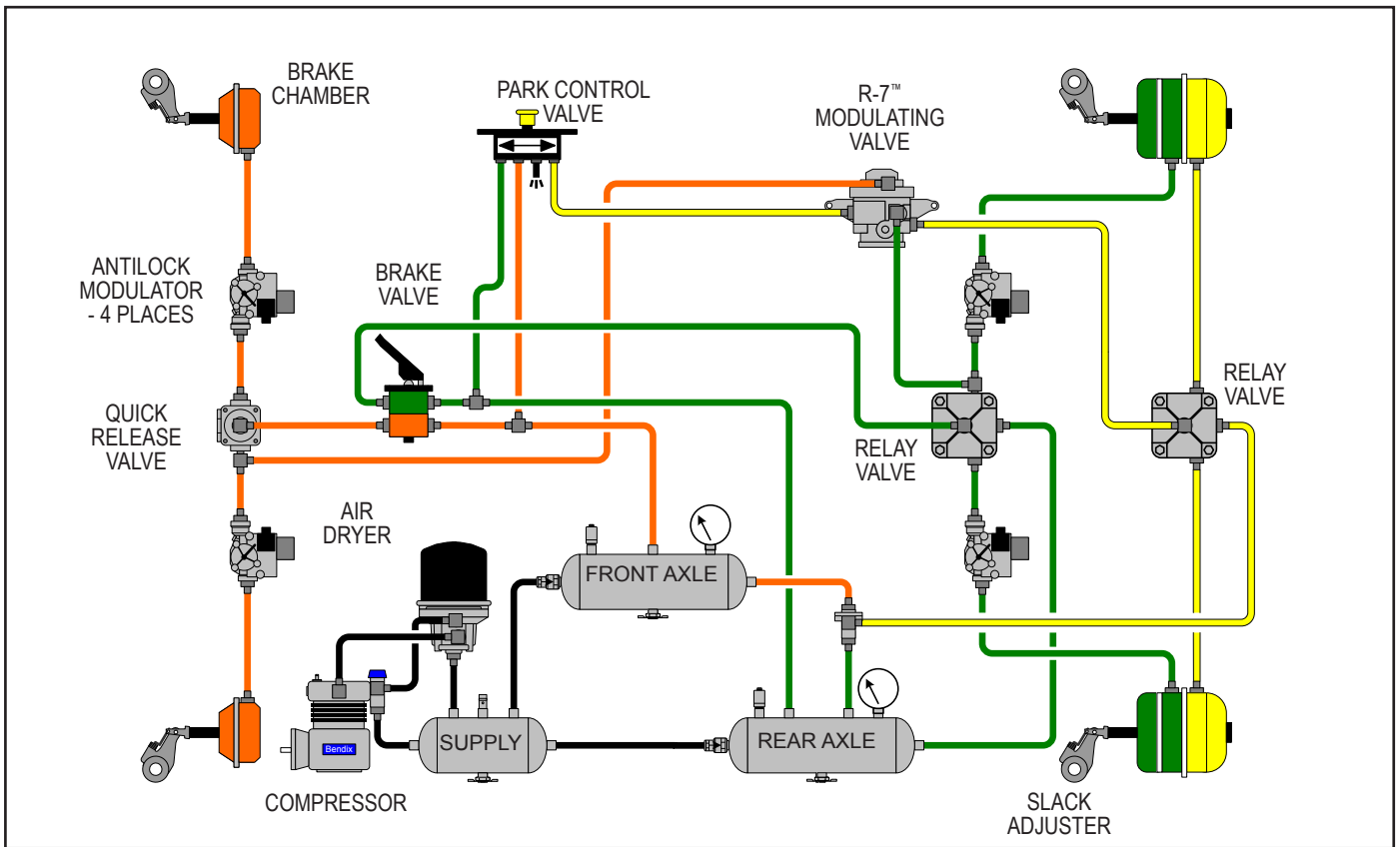

FIGURE 3 - TYPICAL SYSTEM SCHEMATIC

OPERATION - CHARGING SPRING BRAKE ACTUATORS (FIGURE 3)

Air pressure used to control the spring brake actuators enters the Bendix® R-7™ modulating valve through the supply port, passing through one side of the double check valve, through the open inlet valve, over the balance piston, and out the delivery ports to the spring brake actuators. When air pressure in the spring brake actuator cavity has released the spring brake actuators—and when air pressure on top of the balance piston is sufficient to overcome the force of the balance piston spring—the balance piston moves, allowing the inlet valve spring to close the inlet valve. This in turn, shuts off further air pressure from the reservoir supplying the modulating valve.

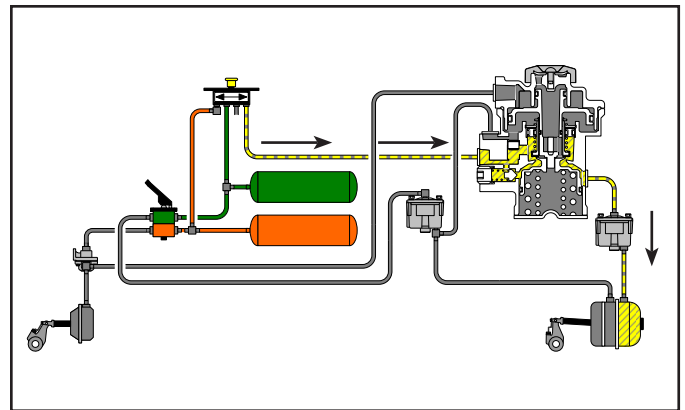

FIGURE 3A - CHARGING - PARKING BRAKE SUPPLY LESS THAN BALANCE PISTON SETTING

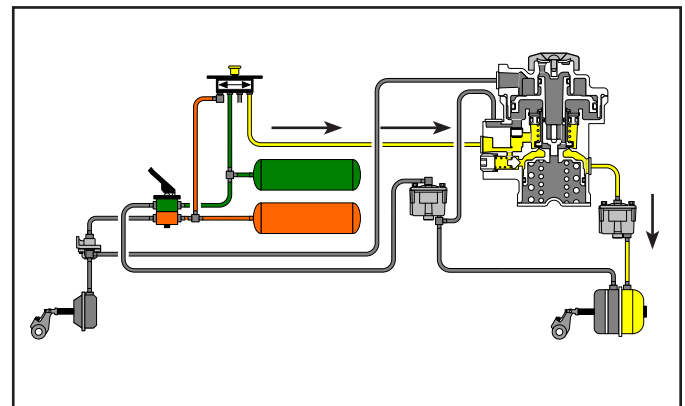

FIGURE 3B - CHARGING - PARKING BRAKE SUPPLY EQUAL TO OR GREATER THAN BALANCE PISTON SETTING

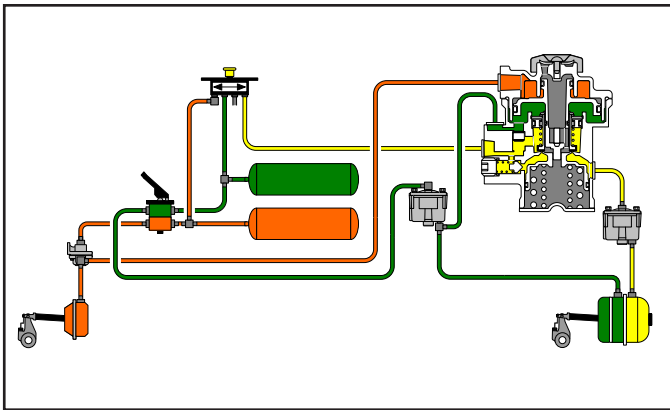

FIGURE 4 - NORMAL SERVICE APPLICATION

OPERATION - NORMAL SERVICE APPLICATION (FIGURE 4)

When a service application is made by actuating the dual brake valve, air from the primary circuit is delivered to the lower side of the control piston through the balance port, and air from the secondary circuit is delivered to the top of the control piston through the control port. Because air pressure from the primary and secondary circuits are not equal, there will be a slight movement of the control piston.

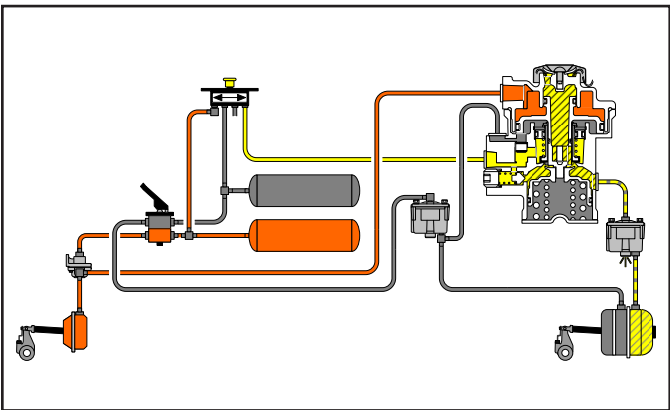

FIGURE 5 - SERVICE APPLICATION LOSS OF PRIMARY CIRCUIT

OPERATION - SERVICE APPLICATION WITH LOSS OF AIR IN PRIMARY CIRCUIT (FIGURE 5)

A service application made with a loss of air in the primary circuit would result in reduced air pressure delivered to the lower area of the control piston. Air pressure from the secondary circuit on top of the control piston would force the piston down, opening the exhaust valve and allowing air pressure in the spring cavity of the spring brake actuator to release and the spring brake actuator to apply the brakes.

The pressure differential between the primary and secondary circuits regulates the amount of air pressure released from the spring cavity of the spring brake actuator. This results in a total brake application on the rear axle which is proportionate to the braking on the other axles.

OPERATION - SERVICE APPLICATION WITH LOSS OF AIR IN SECONDARY CIRCUIT (FIGURE 6)

A service application made with a loss of air in the secondary circuit would result in less, or no, air delivered to the top of the control piston. However, the piston would not move and braking on the rear axle(s) is assured because the primary circuit supplies rear axle service brakes. The spring brake actuators will not be actuated.

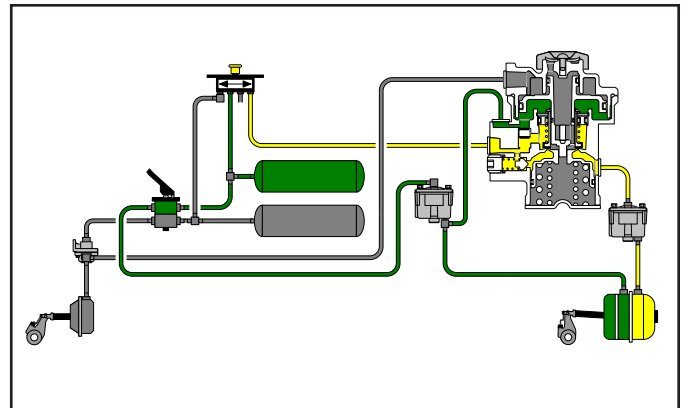

FIGURE 6 - SERVICE APPLICATION LOSS OF SECONDARY CIRCUIT

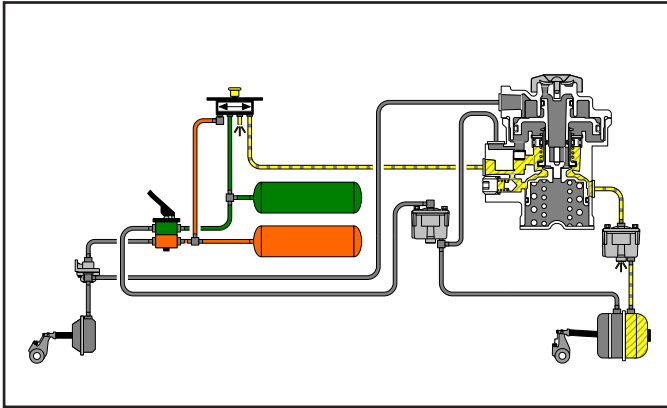

FIGURE 7 - PARKING

OPERATION - PARKING (FIGURE 7)

When the handle of the parking control valve is placed in the “park” (exhaust) position, the modulating valve’s supply air pressure, along with the air pressure in the spring brake actuator cavities is exhausted. The single check valve speeds the exhaust of air from the actuator cavities by allowing the air on top of the balance piston to exhaust by the double check valve through the supply port to atmosphere. When air pressure drops sufficiently, the balance piston opens the inlet valve, thus opening the larger passage in the modulating valve. This ensures rapid exhaust of the balance of air pressure in the spring cavity of the spring brake actuator.

PREVENTIVE MAINTENANCE



Review the Bendix Warranty Policy before performing any intrusive maintenance procedures. A warranty may be voided if intrusive maintenance is performed during the warranty period.

No two vehicles operate under identical conditions, and that means, maintenance intervals may also vary. Experience is a valuable guide in determining the best maintenance interval for air brake system components. At a minimum, the Bendix® R-7™ modulating valve should be inspected every six (6) months or 1500 operating hours, whichever comes first, for proper operation. Should the R-7 valve not meet the elements of the operational tests noted in this document, further investigation and service of the valve may be required.

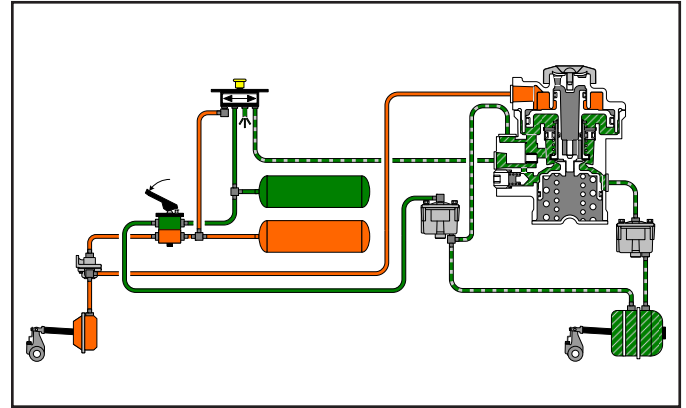

FIGURE 8 - ANTI-COMPOUNDING WHILE PARKING

OPERATING TEST

Block the vehicle and hold it by means other than the vehicle brakes. Charge the air brake system to governor cut-out pressure.

1. Place the parking control valve in “park” position. Observe that the spring brake actuators apply promptly. Remove the air line from the delivery port of valve and install a test gauge known to be accurate. Place the parking control valve in the “release” position. Observe that the spring brake actuators release fully.
2. With the parking control valve in the “release” position, note the gauge pressure reading. (Check the vehicle manual for correct spring brake actuator hold-off pressure.)
3. Place the parking control valve in the “park” position—the gauge reading should drop to zero promptly. A lag—more than one (1) second—in drop of pressure would indicate faulty operation of the single check valve (within the modulating valve).
4. With the parking control valve in the “park” position, fully apply the foot brake valve several times and note a pressure reading increase on the gauge each time the brake is applied. If the pressure reading does not occur, the modulating valve must be either serviced or replaced.
5. Place the parking control valve in the “release” position. Identify the reservoir which supplies the balance port and drain it completely.

Apply the foot brake valve several times and note that the pressure reading on the gauge decreases each time the foot brake valve is applied. After the foot brake valve has been applied several times, pressure on the gauge will drop to the point where the release of the spring brake actuators will no longer occur.

LEAKAGE TEST

Place the park control valve in the “release” position; using a soap solution, coat the exhaust and vent hole (in the proximity of the adjusting screw). Slight bubble leakage is permitted.

If the Bendix® R-7™ valve does not function as described, or if leakage is excessive, it is recommended that it be repaired or replaced with a genuine Bendix® service replacement valve.

DISASSEMBLY

1. Remove the exhaust cover screw, exhaust cover and exhaust diaphragm.
2. Remove the four (4) cap screws, and lockwashers and cover. Remove the o-ring from the cover.
3. Remove the control piston and remove three (3) o-rings from the control piston.
4. Remove the large retaining ring from the body and remove the inlet/exhaust valve assembly.
5. Remove the retaining ring from the inlet/exhaust valve assembly. Remove the o-ring retainer, and the o-ring from the o-ring retainer. Remove the washer and spring. Remove the valve retainer and the valve from the valve body.
6. Remove the four (4) cap screws from the other cover.
7. Remove the cover, along with the inner and outer springs.
8. Remove the balance piston. Remove the o-ring from the balance piston.
9. Remove the retaining ring from the supply port and remove the supply adapter and double check valve assembly. Remove the o-ring from the supply adapter. Remove the double check valve from the shuttle guide. (NOTE: To ease removal of the supply adapter, a pipe nipple can be screwed into the adapter.)
10. Remove the Allen head plug from the single check valve service port. Remove the single check valve assembly. (If the single check valve is difficult to remove, it can be dislodged inside the bore of the body of the valve).

ASSEMBLY

Before assembly, lightly lubricate all o-rings, bores and mating surfaces with silicone lubricant BW-650-M (Bendix Pc. No. 291126).

1. Install the single check valve assembly and Allen head plug. Tighten securely.
2. Install the o-ring on supply adapter, install the shuttle guide over the supply adapter and install the double check valve in the guide.

3. Install the adapter and double check valve assembly in the supply port. Install the retaining ring, making certain the retaining ring is engaged in groove.
4. Install the o-ring on the balance piston then install the balance piston in the bore of the body.
5. Install the inner and outer springs and spring seat (note that the cone shaped protrusion on spring seat faces the springs).
6. Install the cover with four (4) cap screws, torque to approximately 45 in-lbs.
7. Install the valve on valve body. Install the valve retainer, spring, and washer. Install the o-ring on the o-ring retainer. Install the o-ring retainer, compress the retainer and install the retaining ring. Make certain the retaining ring is engaged in the groove of the valve body.
8. Install the inlet/exhaust valve assembly in body. Install the retaining ring making certain the retaining ring is engaged in the groove in the bore of the body.
9. Install the three (3) o-rings on the control piston. Install the control piston in the body. (The larger diameter stem should point up).
10. Install the o-ring on the cover. Install the cover with the four (4) cap screws and lockwashers. Torque to approximately 100 in-lbs.
11. Install the exhaust diaphragm and exhaust cover.

TESTING REBUILT BENDIX® R-7™ MODULATING VALVES

Perform the operating and leakage tests as outlined in the “Service Tests” section.

Log-on and Learn from the Best

On-line training that's available when you are —24/7/365.
Visit www.brake-school.com.

