

Bendix® TABS-6™ Standard and Premium Trailer ABS Modules

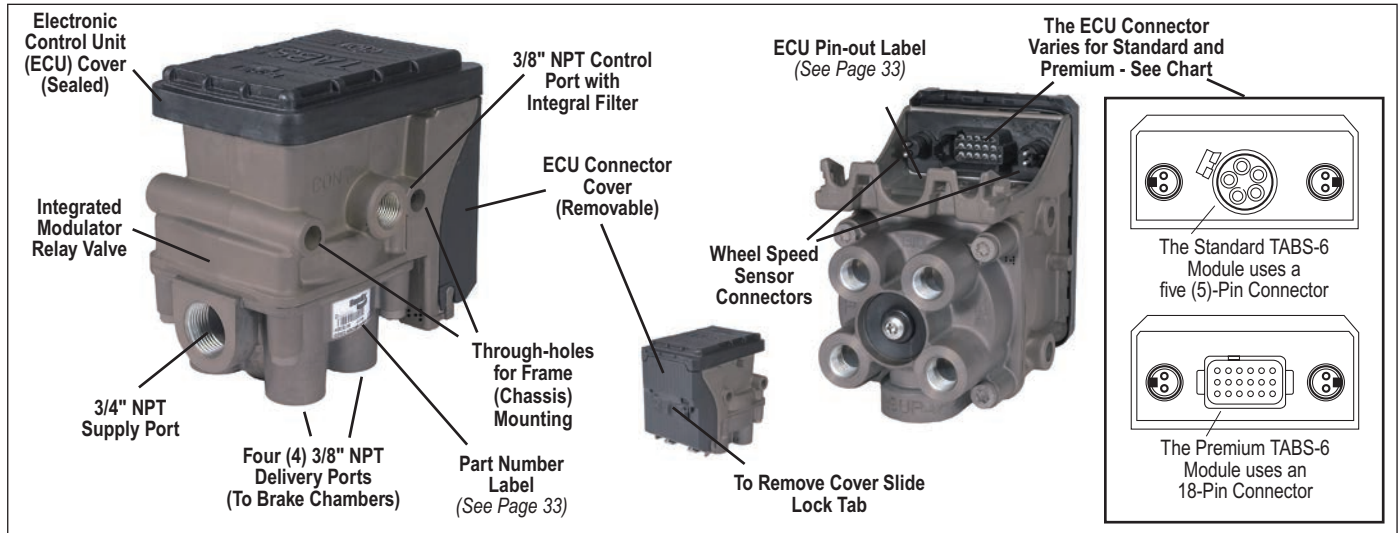

FIGURE 1 - BENDIX® TABS-6™ STANDARD AND PREMIUM MODULES

INTRODUCTION

The Bendix® TABS-6™ module is an integrated trailer ABS controller and modulator for air-braked heavy-duty trailers, semi-trailers and dollies. The module acts as a relay valve during normal braking, but during ABS events, it will intervene to help improve stability. All modules include an Electronic Control Unit (ECU) and Modulator Relay Valve (MRV) which are integrated into a single self-contained 2S/1M (two-sensor, one modulator) trailer ABS unit. The **Premium Bendix TABS-6 module** is auto-configurable to control more sensors and modulators (up to 4S/3M) from its default 2S/1M.

Bendix TABS-6 modules also feature:

- Internal electrical connections to the primary MRV, eliminating the need for external pigtail harnesses.
- Optional mounting to the service reservoir or to the chassis, without additional brackets.
- Blink code diagnostics and support for advanced diagnostic tools.
- Support for Power Line Carrier (PLC) communication to the towing vehicle.
- A pressure equalizing valve in the sealed ECU housing to give improved protection from water, etc.
- A locking dust cover to provide additional electrical connector and cable protection.
- A serviceable nylon filter to help prevent foreign material from entering the control port.

TABLE OF CONTENTS

PAGE

Introduction	1
General Safety Guidelines	2
Components	2
Mounting Configurations	3
PLC Communications	3
Wiring Harness (Pigtail)	3-4
Power and Ground	4
ABS Indicator Lamp	5
Wheel Speed Sensors	5-6
Bendix® BR9235™ ABS Modulator Valves	6
J1708/J1587 Diagnostic Link	7
Auxiliary I/O	7
Bendix® Flex™ ABS Program	7
Customer Scratch Pad	7
Power-up Sequence	7-8
ABS Operation	8
Auto-Configuration	8
Odometer Function	8
Non-standard Tire Size	9
Diagnostic Trouble Code Detection	9
Partial ABS Shutdown	10
Blink Code Diagnostics	10
Diagnostic Trouble Codes (DTCs)	11-13
Using Hand-Held or PC-Based Diagnostics	14
Bendix ABS Diagnostic Tools	14-15
Contacting Bendix	15
Servicing the Bendix TABS-6 Module	16
Service Replacement of Other ABS Controllers	16
Leakage and Operational Tests	17
ABS Wiring	18
Troubleshooting	19-32

COMPONENTS

Installations of the Bendix® TABS-6™ module typically utilize the following components:

- Two or four Bendix® WS-24™ wheel speed sensors (depending on the configuration). Each sensor is installed with a Bendix Sensor Clamping Sleeve. *See page 5.*
- A trailer-mounted ABS indicator lamp. *See page 5.*
- Zero, one, or two Bendix® BR9235™ Pressure Modulator Valves (depending on configuration). *See page 6.*
- Pigtail wiring harness(es) as needed. *See page 4.*

GENERAL SAFETY GUIDELINES



WARNING! PLEASE READ AND FOLLOW THESE INSTRUCTIONS



TO AVOID PERSONAL INJURY OR DEATH:

When working on or around a vehicle, the following guidelines should be observed **AT ALL TIMES**:

- ▲ Park the vehicle on a level surface, apply the parking brakes and always block the wheels. Always wear personal protection equipment.
- ▲ Stop the engine and remove the ignition key when working under or around the vehicle. When working in the engine compartment, the engine should be shut off and the ignition key should be removed. Where circumstances require that the engine be in operation, **EXTREME CAUTION** should be used to prevent personal injury resulting from contact with moving, rotating, leaking, heated or electrically-charged components.
- ▲ Do not attempt to install, remove, disassemble or assemble a component until you have read, and thoroughly understand, the recommended procedures. Use only the proper tools and observe all precautions pertaining to use of those tools.
- ▲ If the work is being performed on the vehicle's air brake system, or any auxiliary pressurized air systems, make certain to drain the air pressure from all reservoirs before beginning ANY work on the vehicle. If the vehicle is equipped with a Bendix® AD-IS® air dryer system, a Bendix® DRM™ dryer reservoir module, or a Bendix® AD-9si® air dryer, be sure to drain the purge reservoir.
- ▲ Following the vehicle manufacturer's recommended procedures, deactivate the electrical system in a manner that safely removes all electrical power from the vehicle.
- ▲ Never exceed manufacturer's recommended pressures.
- ▲ You should consult the vehicle manufacturer's operating and service manuals, and any related literature, in conjunction with the Guidelines above.
- ▲ Never connect or disconnect a hose or line containing pressure; it may whip and/or cause hazardous airborne dust and dirt particles. Wear eye protection. Slowly open connections with care, and verify that no pressure is present. Never remove a component or plug unless you are certain all system pressure has been depleted.
- ▲ Use only genuine Bendix® brand replacement parts, components and kits. Replacement hardware, tubing, hose, fittings, wiring, etc. must be of equivalent size, type and strength as original equipment and be designed specifically for such applications and systems.
- ▲ Components with stripped threads or damaged parts should be replaced rather than repaired. Do not attempt repairs requiring machining or welding unless specifically stated and approved by the vehicle and component manufacturer.
- ▲ Prior to returning the vehicle to service, make certain all components and systems are restored to their proper operating condition.
- ▲ For vehicles with Automatic Traction Control (ATC), the ATC function must be disabled (ATC indicator lamp should be ON) prior to performing any vehicle maintenance where one or more wheels on a drive axle are lifted off the ground and moving.
- ▲ The power **MUST** be temporarily disconnected from the radar sensor whenever any tests **USING A DYNAMOMETER** are conducted on a vehicle equipped with a Bendix® Wingman® system.



WARNING

Disconnect the electrical connectors from the ABS/TRSP Controller before welding on the trailer.



WARNING

Dielectric grease should be applied to electrical connectors to help protect against moisture intrusion.

MOUNTING CONFIGURATIONS

⚠ WARNING

For all NPT fittings use of a thread sealant is required. For NPTF fittings the use of a thread sealant is recommended, this can be a pre-applied or a hand applied sealant product (with PTFE). When using a hand-applied sealant, use caution so as not to over apply. Always follow the fitting manufacturer's pre-applied or hand-applied thread sealant recommendations. Use of PTFE tape is not approved and will void the Bendix® ABS/TRSP™ valve warranty.

Tank (Nipple) Mount

The Bendix® TABS-6™ modules can be tank-mounted using a schedule 80 (heavy gauge steel) 3/4" NPT nipple directly between the trailer supply tank and the module's supply port. A tank with a reinforced port must be used.

Frame (Chassis) Mount

The Bendix TABS-6 module provides through-holes for frame mounting directly to the trailer frame rail or cross-member. It is recommended to use two Grade 5 3/8-16 bolts, typical length 5", torqued to 180-220 in-lbs.

POWER LINE CARRIER (PLC) COMMUNICATIONS

Since March 1, 2001, all new towed vehicles transmit a signal over the power line to an in-cab trailer ABS Indicator Lamp. The signal, using a heavy vehicle industry standard known as "PLC4Trucks," is typically broadcast by the trailer ABS Electronic Control Unit (ECU) over the blue wire (ignition/power line) of the SAE J560 connector. See *Figures 2 and 3*.

Bendix TABS-6 modules support PLC communications in accordance with SAE J2497.

Identifying and Measuring the PLC Signal

A Bendix TABS-6 module will continuously broadcast PLC messages that indicate trailer ABS status. At power-up or during a trailer ABS Diagnostic Trouble Code (DTC) condition, the Bendix TABS-6 module will signal the tractor ABS unit to illuminate the dash-mounted trailer ABS indicator lamp.

Diagnostic tools are available that detect the presence of a PLC signal and perform further system diagnostics directly on the power line. For more information on these diagnostic tools, contact Bendix or refer to your local authorized Bendix dealer or distributor.

An oscilloscope can also be used to verify the presence and strength of a PLC signal on the power line. The PLC signal is an amplitude and frequency modulated signal. Depending on the load on the power line, the amplitude of the PLC signal can range from 5.0 mV p-p to 7.0 V p-p.

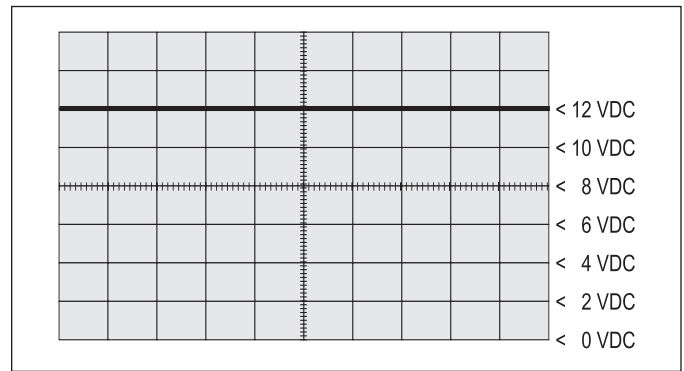

FIGURE 2 - POWER LINE WITHOUT PLC SIGNAL

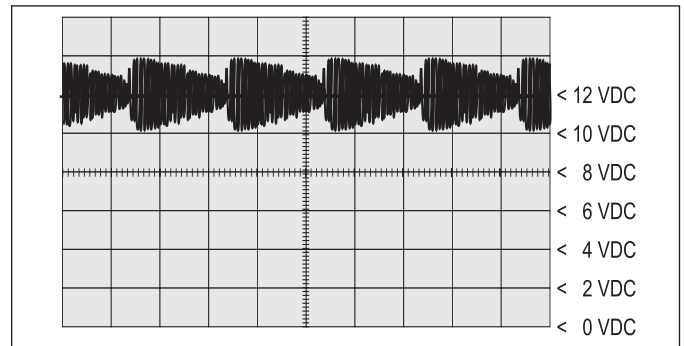

FIGURE 3 - POWER LINE WITH PLC SIGNAL

Suggested oscilloscope settings are (AC coupling, 1 volt/div, 100 μ sec/div). The signal should be measured on pin seven (7) of the J560 connector at the nose of the trailer.

PIGTAIL WIRING HARNESES

Several pigtail wire harnesses are available to connect the Bendix TABS-6 module with ABS and other trailer system components. See *Figure 4*. Pigtail harness are weather sealed at the connector interface and are clearly labeled for proper installation. Because of the over-molded design of the TABS-6 module wiring harnesses, Bendix recommends that the complete harness be replaced if damage or corrosion occurs.

The following connector options may be present:

Modulator 2 (MOD2), Modulator 3 (MOD3), auxiliary, diagnostic, and additional axle wheel speed sensors.

Note: All Bendix TABS-6 modules include the two primary wheel speed sensor connections and therefore these are separate from the pigtail harness.

ECU Connectors

Standard Bendix TABS-6 module ECU connectors use a TTMA 97-99 5-pin Delphi Weather Pack connector for brake light power, constant power, ground, and the trailer-mounted ABS indicator lamp.

Premium Bendix TABS-6 module ECU connectors use an 18-pin Deutsch DT series connector for the same function as above, plus additional modulators, wheel speed sensors and auxiliary I/O's.

Power/ABS Indicator Lamp Connector

The Bendix® TABS-6™ module pigtail uses a TTMA RP 97-99 five (5)-pin Delphi Weather Pack connector for brake light power, constant power, ground and the trailer-mounted ABS indicator lamp.

The Power/ABS indicator lamp lead of the pigtail harness is available in several lengths to satisfy most installation requirements (e.g. slider axles).

Wheel Speed Sensor Connectors

Two (2)-pin connectors are provided for additional wheel speed sensors for 4S ABS applications. These connectors are labeled Additional Sensor Left (SAL), and Additional Sensor Right (SAR). Extension cables are available in various lengths from Bendix.

ABS Modulator Connectors

On Premium Bendix TABS-6 module pigtail harnesses, one or two modulator connectors are provided for trailers using two or three modulators. These three (3)-pin connectors are labeled MOD2 and MOD3. (Note: MOD1 designates the internal modulator of the Bendix TABS-6 module). Remote modulator harnesses are available in many lengths to satisfy most installation requirements.

Diagnostic Connector

Premium Bendix TABS-6 module pigtail harnesses provide a four (4)-pin diagnostic connection for a diagnostic tool to monitor Electronic Control Unit (ECU) ignition power, ground and data information. Remote diagnostic cables are available from Bendix to provide a standard J1708/J1587 diagnostic port at the side of the trailer.

Auxiliary I/O Connector

An optional auxiliary connector provides a connection to the Bendix TABS-6 module auxiliary I/O ECU pins. Premium ECU pigtails provides an option for up to six auxiliary I/O's.

POWER AND GROUND

Trailer electrical power is supplied to the Bendix TABS-6 module from the ignition and brake light circuits. See Charts 1 and 2 for output values and pin locations.

Function Mode	Value
Operating Range	8.0 to 16.0 VDC
ECU Active	135 mA @ 12 VDC
ABS Active (1 Modulator)	3.7 A @ 12 VDC
ABS Active (2 Modulators)	5.2 A @ 12 VDC

CHART 1 – VALUES FOR OUTPUTS

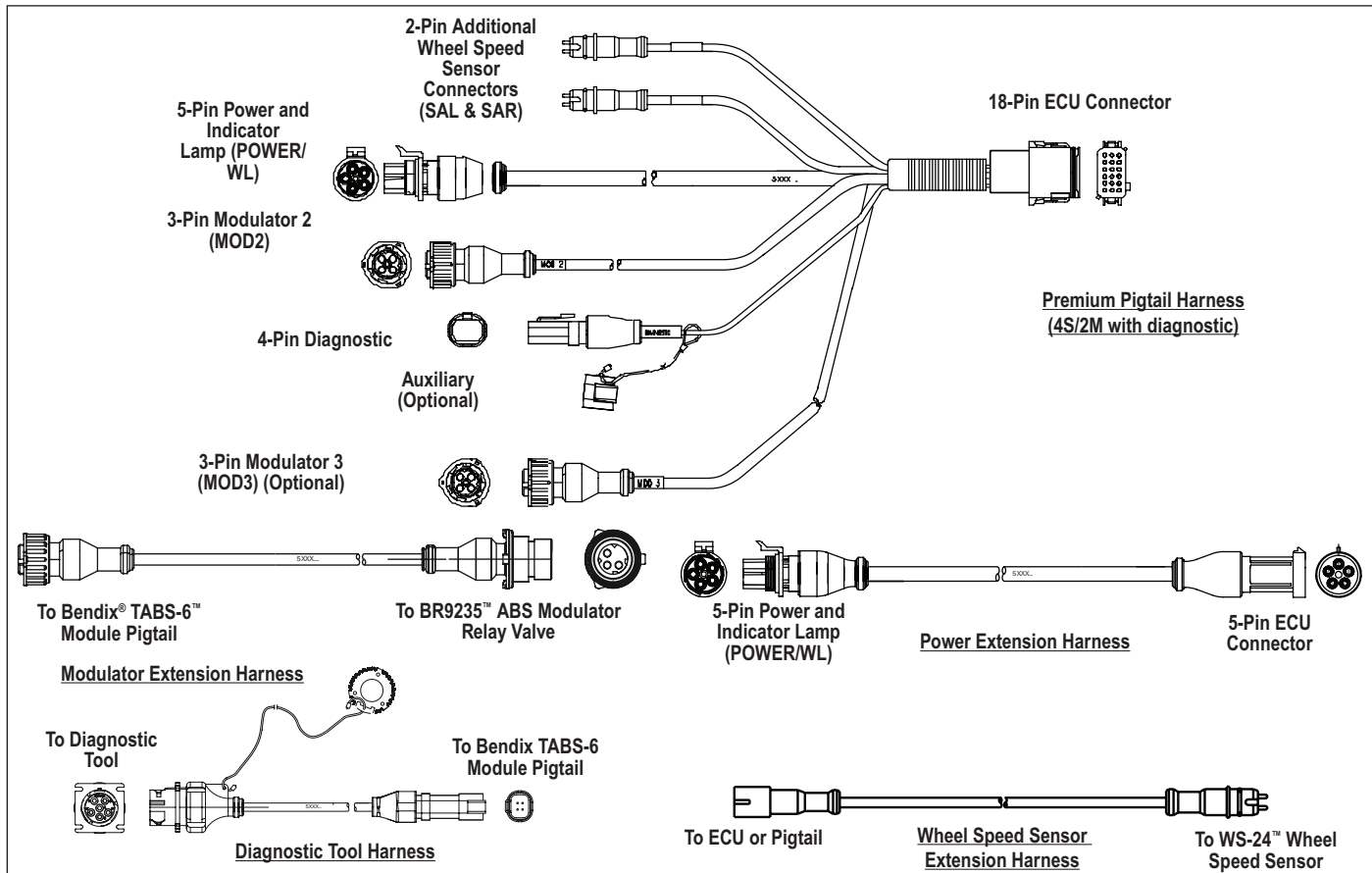

FIGURE 4 - EXAMPLES OF PIGTAIL WIRE HARNESSES AVAILABLE

Circuit	7-Pin Trailer Conn.	5-Pin ABS Conn.	5-Pin ECU Conn.	18-Pin ECU Conn.
Ignition Power PLC (Blue Wire)	7	B	B	6
Brake Light Power (Red Wire)	4	A	A	12
Ground (White Wire)	1	E	E	18
Indicator Lamp (White/Green Wire)	N/A	D	D	5

CHART 2 – POWER AND GROUND

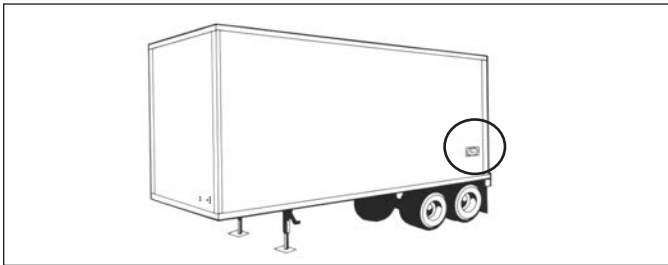

FIGURE 5 - TRAILER-MOUNTED ABS INDICATOR LAMP

ABS INDICATOR LAMP

Trailer-mounted Lamp

The Bendix® TABS-6™ module controls an ABS indicator lamp to show the trailer ABS status. With power supplied by the towing vehicle, the module illuminates the ABS indicator lamp by providing a 12.0 VDC signal. (The other side of the lamp is grounded.) The ABS indicator lamp output uses Pin D of the five (5)-pin Standard module connector, and Pin 5 of the 18-pin Premium module connector.

Dash-mounted Lamp (PLC Controlled)

Bendix TABS-6 modules use SAE J2497 standards to support Power Line Carrier (PLC) communication. The Bendix TABS-6 module transmits a signal over the power line to the towing vehicle. This information is used by towing vehicle's ABS controller to know when to illuminate the trailer ABS indicator lamp mounted on the dash.

The status of the trailer ABS is transmitted over the ignition power wire (blue wire of the J560 connector), Pin B of the five (5)-pin Standard module connector, or Pin 6 of the 18-pin Premium module connector.

BENDIX® WS-24™ WHEEL SPEED SENSORS

Wheel speed data is provided to the Bendix TABS-6 module from the WS-24™ wheel speed sensors (see Figure 6). Vehicles have an exciter ring (or "tone ring") as part of the wheel assembly, and as the wheel turns, the teeth of the exciter ring pass the wheel speed sensor, generating an AC signal. The Bendix TABS-6 module receives the AC signal, which varies in voltage and frequency as the wheel speed

changes. (The default setting expects a 100-tooth tone ring to be used.) Vehicle axle and ABS control configurations determine if two or four wheel speed sensors are required. See page 19 for electrical system schematics showing wheel speed sensor connector pin locations.

A proper sensor installation is critical to correct ABS operation.

Typically, the WS-24™ sensor is installed in mounting blocks that are welded to the axle housing. WS-24™ wheel speed sensors are protected by a stainless steel sheath. They are designed to be used with beryllium copper clamping sleeves (sometimes referred to as a "retainer bushing", "friction sleeve" or "clip") (See Figure 6). The clamping sleeve provides a friction fit between the mounting block bore and the WS-24™ sensor.

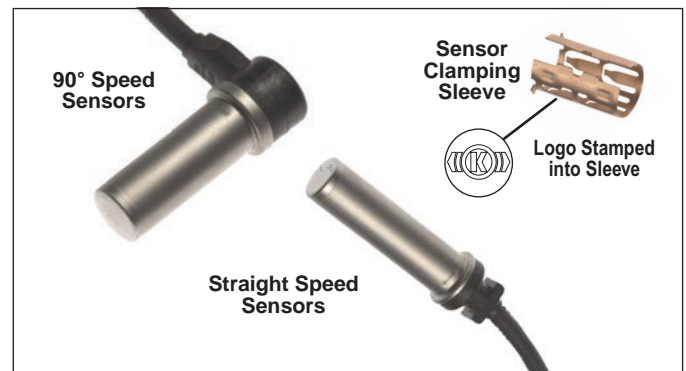

FIGURE 6 - BENDIX® WS-24™ WHEEL SPEED SENSORS

1. For increased corrosion protection we recommend that a high-temperature rated silicon- or lithium-based grease be applied to the interior of the mounting block, the sensor, and to a new clamping sleeve.
2. Install the new clamping sleeve fully into the block, with the retaining tabs toward the inside of the vehicle. Please note that WS-24™ wheel speed sensors must use the correct clamping sleeve to avoid problems associated with reduced retention force, such as sensor movement and resulting ABS trouble codes.

WARNING

Use of cable ties/tie wraps to attach wheel speed sensor leads to rubber hoses/jounce lines is not approved. The hose may expand during braking due to air pressure and the cable tie may not, so the conductor material/insulation of the speed sensor extensions may be damaged. Bendix instead recommends only open-ended clips be used to hold sensor leads to jounce lines.

3. Gently push (DO NOT STRIKE) the sensor into the mounting block hole until it bottoms out on the face of the tone ring. Secure the cable lead wire to the knuckle/ axle housing three to six (3-6) inches from the sensor. See Figure 7.

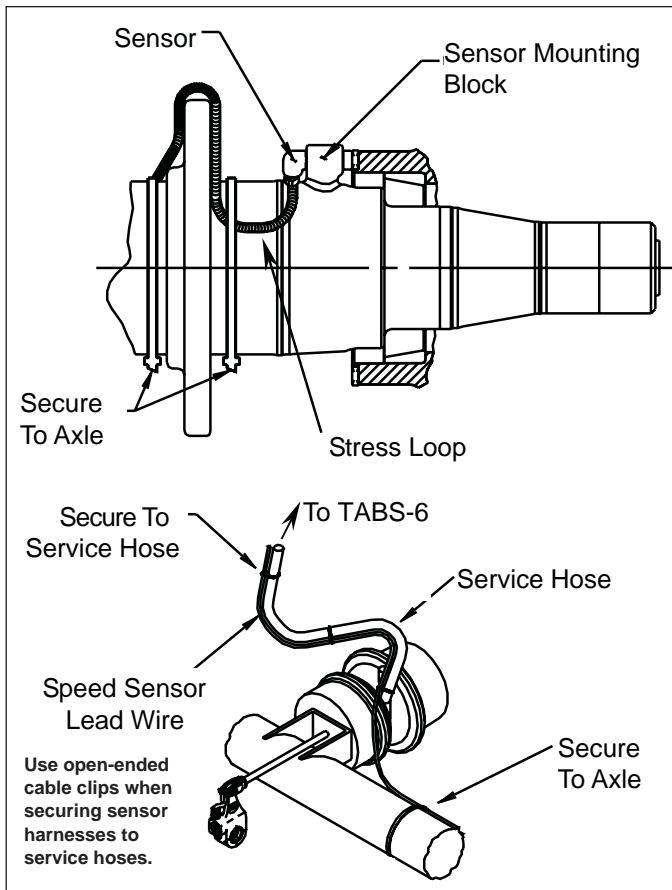

FIGURE 7 - SENSOR LEAD ROUTING AND SECURING

4. Apply a moderate amount of dielectric non-conductive grease to both the sensor connector and harness connector.
5. Engage the connectors, and push together until the lock tab snaps into place.

NOTE: It is important for the wheel bearings to be adjusted per the manufacturer's recommendations.

The friction fit allows the Bendix® WS-24™ sensor to slide back and forth under force but to retain its position when the force is removed. When the Bendix WS-24 sensor is inserted all the way into the mounting block and the wheel is installed on the axle, the hub exciter contacts the sensor, which pushes the sensor back. Also, normal bearing play will “bump” the sensor away from the exciter. The combination of these two actions will establish a running clearance or air gap between the sensor and exciter.

Excessive wheel end play can result in diagnostic trouble codes in cases where the sensor is pushed too far away from the tone ring.

Use open-ended cable clips when securing sensor harnesses to service hoses.

BENDIX® BR9235™ ABS MODULATOR RELAY VALVES

Bendix® BR9235™ modulator relay valves (MRV) are required when additional modulator relay valves are needed for multichannel brake systems (e.g. 2S/2M, 4S/3M ABS configurations).

The MRV is an electro-pneumatic control valve and is the last valve that air passes through on the way to the brake chambers. The normally-open hold solenoid and normally-closed exhaust solenoid are activated to precisely modify the brake pressure on command. During normal braking, the Bendix BR9235 MRV functions as a standard relay valve. As brakes are applied or released by the driver, the control signal from the tractor foot valve causes the Bendix BR9235 MRV to apply proportional pressure to the trailer brake chambers.

The Bendix BR9235 MRV is available in both tank and bracket mounting styles. See Figure 8.

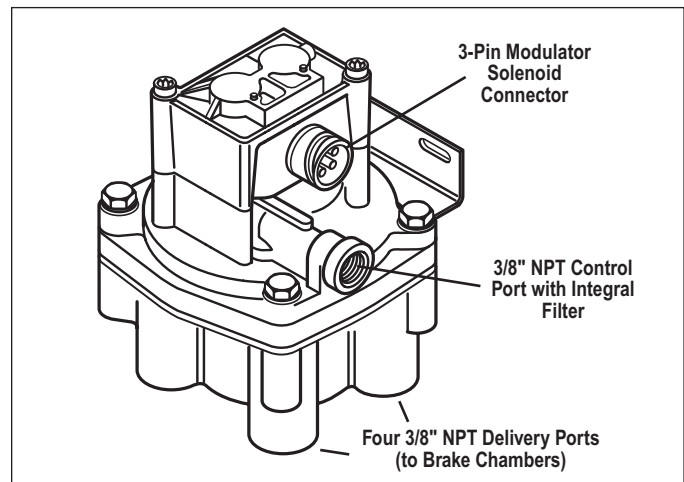

FIGURE 8 - BENDIX® BR9235™ MODULATOR RELAY VALVE

CRACK PRESSURE

Bendix® TABS-6™ Standard modules with a component index of S009 have no spring and are rated at a crack pressure of 3 ± 0.5 psi.

Bendix TABS-6 Standard modules with a component index of S010 and higher have a spring and are rated at a crack pressure of 4.5 ± 0.5 psi.

Modulator Relay Valve (MRV) Crack Pressure

The Bendix TABS-6 ABS modulator relay valves are available with nominal crack pressure of 4.5 ± 0.5 psi. Previous models of Bendix TABS-6 modulator relay valves came with a nominal crack pressure of 3.0 ± 0.5 psi. Installation drawings are available that can provide information on which version you have.

Tank (Nipple) Mounted

The Bendix® BR9235™ Modulator Relay Valve (MRV) can be tank-mounted using a schedule 80 (heavy gauge steel) 3/4" NPT nipple directly between the trailer supply tank and the supply port. A tank with a reinforced port must be used.

Bracket (Chassis) Mounted

The Bendix BR9235 MRV provides an option with a bracket for frame mounting directly to the trailer frame rail or crossmember. It is recommended to use two Grade 5, 3/8-16 bolts, torqued to 180 – 220 in-lbs.

J1708/J1587 DIAGNOSTIC LINK

The Premium Bendix® TABS-6™ module provides a J1708/J1587 diagnostic link with data and power to communicate with the vehicle and various diagnostic tools. Diagnostics, testing, configuration, data transfer and other functions can be performed using this link. Diagnostic tools such as the MPSI Pro-Link™ device and Bendix® ACom® Diagnostic Software (version 6.5 and higher) support the Bendix TABS-6 module.

Ignition power must be provided to the Bendix TABS-6 module for the diagnostic link to be active.

AUXILIARY I/O

The Standard module provides for one auxiliary I/O function.

The Premium module provides for up to five auxiliary functions and one additional ground. See Chart 3, below.

Bendix® ACom® Diagnostic Software (version 6.5 and higher) supports the configuration of the Bendix TABS-6 module auxiliary I/O's.

BENDIX® FLEX™ ABS PROGRAM

A Bendix® Flex™ ABS program uses Auxiliary Design Language (ADL) to allow customized auxiliary functions to be carried out by the Bendix TABS-6 module. Functions developed in the Bendix Flex ABS program may be downloaded at the production line or in the field to control non-braking functions of the trailer.

For example, a Bendix Flex ABS program can potentially communicate the status of: tire inflation and/or temperature; reefer temperature; load presence; slider-pin position; lift axle position; proximity/reverse alarm; and vehicle weight.

The Bendix Flex ABS program can monitor the auxiliary I/Os and/or the SAE J1587 diagnostics and SAE J2497 PLC data links. Contact your Bendix Account Manager to discuss a Bendix Flex ABS program for your vehicle(s).

CUSTOMER SCRATCH PAD

The Bendix TABS-6 module has a Customer Scratch Pad feature which allows the customer, or end-user, to store up to 756 bytes of information. This information can then be read using the Bendix ACom Diagnostic Software (version 6.5 and higher).

If additional scratch pad space is needed, this storage space can be expanded to 1K (1,008 bytes total of data). Contact Bendix for further details.

POWER-UP SEQUENCE

At power-up, the Bendix TABS-6 module performs a series of self-checks that can assist a technician to determine the ABS system status and configuration.

Trailer ABS Indicator Lamp

At power-up without detected Diagnostic Trouble Codes (DTCs), the trailer ABS indicator lamp will turn on for 2.5 seconds as a bulb check and then turn off. See Figure 8.

If a PLC-ready towing vehicle and trailer are powered at the same time, the Bendix TABS-6 module will also trigger a bulb check on the dash-mounted trailer ABS indicator lamp.

Modulator Chuff Test at Power-Up

At power-up, the Bendix TABS-6 module activates a modulator chuff test. This electrical and pneumatic ABS modulator test can help the technician identify problems with modulator installations and/or wiring.

With brake pressure applied, a properly installed modulator will cause five (5) rapid audible chuffs of air pressure. If additional modulators are installed, the Bendix TABS-6 module activates five (5) chuffs at the internal modulator (MOD1) then five (5) chuffs for each additional modulator in sequence (e.g. MOD1, then MOD2, and then MOD3). The chuff sequence is then repeated.

If the modulator is wired incorrectly, the modulator will only produce one chuff, or no chuff at all. If an issue is detected during the modulator chuff test, compare the modulator wiring and plumbing to the Bendix TABS-6 module's electrical system schematic (see page 19) and make repairs.

Name	ECU	ECU Pin	Auxiliary Functions	Default Function
AUX1	Premium	16	• High-Side Driver... or Digital Input	Modulator 3 (MOD3) Hold Solenoid
AUX2	Premium	10	• High-Side Driver... or Digital Input	Modulator 3 (MOD3) Release Solenoid
AUX3	Premium	15	• High-Side Driver... or Digital Input	Modulator 2 (MOD2) Hold Solenoid
AUX4	Premium	9	• High-Side Driver... or Digital Input	Modulator 2 (MOD2) Release Solenoid
AUX5	Premium	4	• Low-Side Driver... or Analog Input	Modulator 3 (MOD3) Common
AUX6	Premium	2	• High-Side Driver... or Digital Input	J1587 Diagnostic Power

CHART 3 – AUXILIARY I/Os AND DEFAULT FUNCTIONS

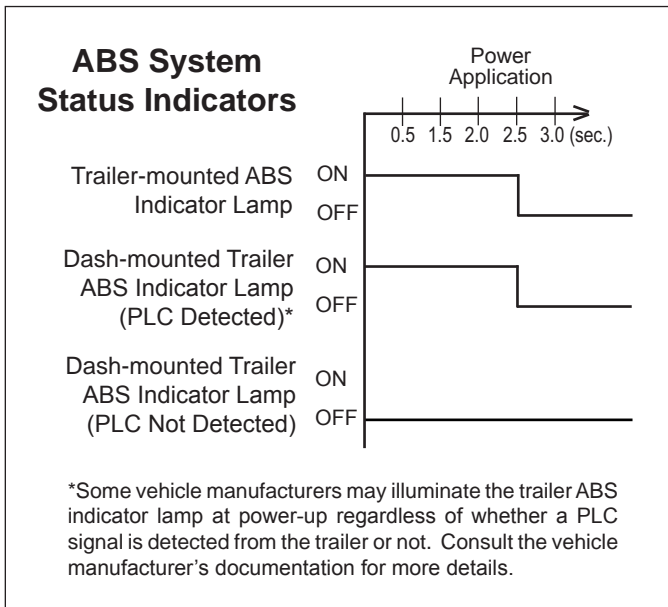

FIGURE 8 - TRAILER ABS LAMP START-UP SEQUENCE

ABS OPERATION

The Bendix® TABS-6™ module uses wheel speed sensors, modulator relay valves and an Electronic Control Unit (ECU) to control trailer wheels by axle or by side. By monitoring individual wheel turning motion during braking, and adjusting or pulsing the brake pressure at each wheel, the Bendix TABS-6 module is able to optimize slip between the tires and the road surface. When excessive wheel slip, or wheel lock-up, is detected, the ECU will activate the Pressure Modulator Valves to modulate braking pressure at the wheel ends. The ECU is able to pump the brakes on individual wheels (or pairs of wheels), independently, and with greater speed and accuracy than a driver.

Axle Control

Bendix TABS-6 module axle control uses a single modulator relay valve to control wheels on both sides of a given axle or axles. In the case of an ABS event on road surfaces with poor traction (worn, slippery, or loose gravel roads) or areas of poor traction, (e.g. asphalt road surfaces with patches of ice), axle control will maintain the wheel that is not slipping at just under the speed that will lock the wheel. Temporary periods of wheel lock are permitted on the other wheel that is experiencing slippage.

Axle control should not be used on 5th wheel dollies or steerable axles. When braking on even surfaces, an axle-control system will perform similar to a side control, two-modulator system. Axle control is available in 2S/1M, 2S/2M and 4S/2M installations, and for Modulator 3 (MOD3) in a 4S/3M installation.

Dolly-Axle Control (Select Low)

Bendix TABS-6 module dolly-axle control uses a single ABS modulator valve to control wheels from both sides of a given axle or axles. In the case of an unbalanced braking surface, (e.g. asphalt road surfaces with patches of ice),

dolly axle control will control the low coefficient (slipping) wheel just under the lock limit. Vehicle stability is assisted by not allowing the high coefficient wheel (where traction is still being maintained) to sustain wheel lock.

When braking on even surfaces, a dolly axle control system will perform similar to side control or axle control system. Dolly axle control is only available in 2S/1M installations.

Side Control

The Bendix TABS-6 module uses a single modulator relay valve to control one or more wheels on a given vehicle side. In the case of an unbalanced braking surface, the side control will individually control wheels on each side just under the point where they would lock up.

Side control is available in 2S/2M and 4S/2M installations, and for the internal modulator (MOD1) and Modulator 2 (MOD2) in the 4S/3M installation.

Normal Braking

During normal braking, the Bendix TABS-6 module functions as a standard relay valve. If the ECU does not detect excessive wheel slip, it will not activate ABS control, and the vehicle stops with normal braking.

AUTO-CONFIGURATION

The Standard Bendix TABS-6 module is available only in the 2S/1M ABS configuration and does not use auto-configuration.

For the Premium Bendix TABS-6 module, the default ABS configuration is 2S/1M. At power-up, if a Premium ECU detects additional sensors and modulators it will perform an auto-configuration. Auto-configuration only adjusts upward (e.g. 2S/2M Side to a 4S/2M Side configuration).

Additional detected components that do not conform to a legitimate configuration will generate the appropriate Diagnostic Trouble Code (DTCs).

Note: If the vehicle begins moving before the new configuration has been accepted, the reconfiguration will not take place at this time.

ODOMETER FUNCTION

Odometer

The Bendix TABS-6 module includes an odometer function to provide a means of storing the accumulated mileage of the vehicle. The mileage is computed by utilizing information calculated from the vehicle wheel speeds.

This feature is accurate to within 0.62 miles per power-up and will typically store mileage up to 1,000,000 miles. The mileage can be displayed using PC diagnostics or through blink codes.

Whenever the module is towed using a pre-1997 tractor — one that is stop-lamp-powered (SLP) — the electronic odometer does not function, and the mileage can be considered out-of-calibration.

Trip Counter

The module provides a counter to record the trip mileage. The feature is accessed through PC or hand-held diagnostic tools.

MISCELLANEOUS MAINTENANCE



WARNING

GLAD HAND MAINTENANCE

- ▲ **NEVER POUR ANY LIQUIDS** (alcohol, anti-freeze, additives, etc.) into the glad hands. Liquids may cause the o-rings and seals to swell, may result in lubrication loss and leave harmful residues.
- ▲ **Prevent nesting insects and contaminants** from entering and blocking the air hoses. Check that screens are present and clean.
- ▲ **Drain the trailer air tanks** a minimum of every six (6) months.

Liquids/Contamination can cause **TRAILER AIR BRAKE FAILURE** and/or the **INABILITY TO RELEASE** the trailer parking brakes.



WARNING

BENDIX® ABS SYSTEM POWER-UP CHECK

At power-up the trailer ABS indicator lamp should briefly illuminate “ON” as a bulb check.

If the indicator lamp does not illuminate at power-up, the ABS system may not be powered, or the bulb may need to be replaced. Service the trailer ABS system.

- ▲ If the lamp remains “ON” after power-up there may be active Diagnostic Trouble Codes (DTCs). Service the trailer ABS system. (To ensure full ABS/TRSP functionality, service as soon as possible.)

Other Important Practices:

- ▲ **Follow all standard industry safety practices.**
- ▲ **Sealant for ABS Fittings: Use pre- or hand-applied; Never PTFE tape (Voids Bendix ABS Warranty).**
- ▲ **Use open-ended clips (never cable ties) to hold sensor leads to jounce lines.**
- ▲ **Drain the trailer air tanks** a minimum of every six (6) months.
- ▲ **Disconnect the electrical connectors from the ABS Controller** when welding on the trailer.

Service Interval

The Bendix® TABS-6™ module provides a feature that can be used to indicate a service interval for the trailer. The service interval can be accessed via PC or hand-held

diagnostic tools. If configured, the Bendix TABS-6 module can flash the indicator lamp when the vehicle is at standstill to indicate when the service interval has been exceeded.

Default	Additional Components		Auto-Configuration
	Sensors	Modulators	
2S/1M Dolly Axle	-	-	2S/1M (Dolly-Axle)
	-	1	to 2S/2M (Side)
	2	1	to 4S/2M (Side)
2S/1M Axle	2	2	to 4S/3M (Side/Axle)
	-	-	2S/1M (Axle)
	-	1	to 2S/2M (Axle)
	2	1	to 4S/2M (Axle)

CHART 4 – PREMIUM BENDIX® TABS-6™ MODULE AUTO-CONFIGURATION MATRIX

NON-STANDARD TIRE SIZE

The module allows for tire rolling radius and tone ring tooth count parameters to be set for each axle using a diagnostic tool. These adjustments may be necessary for the module to accurately calculate the vehicle velocity and odometer mileage. Wheels of the same axle must be set to the same rolling radius and tone ring tooth count. In most cases, these parameters are set by the trailer OEM and do not need to be adjusted. In the case of a service replacement unit, always check that these parameters are set to match the vehicle.

The tire-rolling radius is defaulted to 500 revs/mile and can be adjusted from 300 to 700 revolutions per mile. Refer to the manufacturer’s tire specification for correct values.

Tone ring tooth count is defaulted to 100 teeth and can be set from 60 to 140 teeth.

DIAGNOSTIC TROUBLE CODE DETECTION

The Bendix TABS-6 module contains self-testing diagnostic circuitry that monitors the ABS components and wiring.

When the module senses an erroneous system condition, it activates the external trailer-mounted ABS indicator lamp, disables all or part of the affected ABS functions, and it stores the DTC code in memory, even when the power is removed. The module also uses PLC communications to send the system status to the towing vehicle.

For some trouble codes, the Bendix TABS-6 module will automatically reset (“self-heal”) the active diagnostic trouble code when the error is corrected (e.g. when a wheel speed sensor is re-aligned). However, repeated occurrences of a given trouble code can cause the code to “latch” - that is, be retained as active, even if the condition is only intermittent. Once the code is latched, a manual reset will be necessary. Technicians can use these latched codes to assist them in troubleshooting intermittent errors. After the problem is repaired, trouble codes can be reset using blink code diagnostics or with a diagnostic tool.

When a trouble code self-heals or is manually reset, the code remains stored in the Electronic Control Unit (ECU) memory. This trouble code history can be retrieved using blink code diagnostics or with a diagnostic tool.

PARTIAL ABS SHUTDOWN

Depending on the trouble code detected, the ABS ECU partly or completely disables the ABS functionality. The trailer ABS system, for vehicles that only have one modulator, is disabled by any single Diagnostic Trouble Code (DTC). In the case of vehicles with two or three modulators, depending on the trouble code, the trailer ABS system may still provide some level of ABS function on axles/wheels that are not affected by the DTC, but the ABS indicator lamp will remain on. In cases where the ABS is completely disabled, the vehicle reverts to normal braking (without ABS interventions). **Always repair ABS shutdowns at the earliest opportunity.**

ECU Diagnostic Trouble Codes

All ABS functions are completely disabled. The system reverts to normal braking.

Voltage Diagnostic Trouble Code

While voltage is out of range, the ABS functionality is disabled and the system reverts to normal braking. When the correct voltage level is restored, full ABS is typically available again. The operating voltage range is 8.0 to 16.0 VDC.

BLINK CODE DIAGNOSTICS

The Bendix® TABS-6™ module provides diagnostic and configuration functions through blink code diagnostics. This means that the technician, even without diagnostic tools, can read a series of ABS indicator lamp blinks to diagnose the trouble codes being generated.

The blink code diagnostics mode is entered by providing constant power to the ignition circuit and toggling the brake light power input three times. With a parked towing vehicle attached, this is done by applying ignition power and after the power-up sequence is complete, depressing and releasing the brake pedal three or more times, see chart 5 below.

Depending on the blink code mode activated, the TABS-6 module will blink the trailer-mounted ABS indicator lamp to display: active DTC codes; DTC code history; ABS configurations; and odometer mileage. Blink code diagnostics can also be used to reset active DTC codes.

With Ignition Power Applied, Cycle Brake Light Power	Blink Code Action
3 times	Display Active DTCs
4 times	Display Inactive DTCs
5 times	Clear Active DTCs
6 times	Display Configuration
7 times	Display Odometer Mileage
8 times	Reset Configuration

CHART 5 – BLINK CODE INFORMATION

Wait until after the modulator chuff test before activating the brake light power — or five (5) seconds if no chuff is heard.

Blink code diagnostics must be activated within the first 15 seconds of ignition power being applied.

If brake light power is continuously applied for greater than five seconds, blink code diagnostics will be disabled until the next time the ignition power is cycled.

Display Active Diagnostic Trouble Codes

To display active codes, apply ignition power and depress/release the brake pedal three (3) times within 15 seconds. Following activation, there will be a five (5)-second delay followed by a blink code display of all active DTC codes. *See pages 11-13 for more information.*

Display Diagnostic Trouble Code History

To display trouble code history, apply ignition power and depress/release the brake pedal four (4) times within 15 seconds. Following activation, there will be a five (5)-second delay followed by a blink code display of all history DTC codes. *See pages 11-13 for more information.*

Reset Active Diagnostic Trouble Codes

To reset active codes, apply ignition power and depress/release the brake pedal five (5) times within 15 seconds. Following activation, there will be a five (5)-second delay followed by a blink code message of:

1-1, (System Fully Operational - No Codes Detected) or a blink code display of all remaining active DTC codes.

The ABS indicator lamp will stay on if active DTCs are still present.

Resetting active DTC codes with blink code diagnostics does not clear information from trouble code history. Both blink code diagnostics or diagnostic tools can retrieve trouble code history, but only diagnostic tools can erase this information.

Display Configuration

To check the ABS configuration, apply ignition power and depress/release the brake pedal six (6) times within 15 seconds. Following activation, there will be a five (5)-second delay followed by a blink code display of the module's current ABS configuration.

1st Digit	Sensors
2	2 Sensors
4	4 Sensors
2nd Digit	Modulators
1	1 Modulator
2	2 Modulators
3	3 Modulators
3rd Digit	ABS Control Mode
1	Axle
2	Side
3	Dolly-Axle
4	MOD1 Axle - MOD2 Dolly-Axle
5	MOD1 Axle - MOD2 Lift Axle Detection
6	Side (MOD1, MOD2) - MOD3 Dolly-Axle

CHART 6 – ABS CONFIGURATIONS

Display Odometer Mileage

To display the trailer odometer mileage, apply ignition power and depress/release the brake pedal seven (7) times within 15 seconds. Following activation, there will be a five (5)-second delay followed by a blink code display of the odometer information (x1000).

Example: 152,431 miles will be displayed as: one (1) blink, (pause), five (5) blinks, (pause), two (2) blinks.

Zeros will be displayed by the ABS indicator lamp strobing twice.

Odometer mileage cannot be altered with blink code diagnostics. Complete odometer information can be retrieved using a diagnostic tool.

Resetting ABS Configuration

To reset the ABS configuration to the default configuration, apply ignition power and depress/release the brake pedal eight (8) times within 15 seconds. Following activation, the Bendix® TABS-6™ ABS configuration will reset to the default ABS configuration (2S/1M), and will self-configure the next time the trailer receives power.

Diagnostic Trouble Codes (DTCs)

1st Digit	2nd Digit	Diagnostic Trouble Code (DTC) Description	J1587 (SID)	J1587 (FMI)	Repair Information	
1	1	No DTCs	1	0	• ABS system fully operational – no DTCs detected	
WHEEL SPEED SENSORS (WSS)						
2	1	SL Sensor signal valid - large air gap	1	0	Dynamic Wheel Speed Sensor DTC. <i>Go to Section G, on Page 31.</i>	
3	1	SR Sensor signal valid - large air gap	2	0		
4	1	SAL Sensor signal valid - large air gap	3	0		
5	1	SAR Sensor signal valid - large air gap	4	0		
2	2	SL Sensor signal valid - loss of signal	1	1		
3	2	SR Sensor signal valid - loss of signal	2	1		
4	2	SAL Sensor signal valid - loss of signal	3	1		
5	2	SAR Sensor signal valid - loss of signal	4	1		
2	3	SL Sensor signal valid – noisy	1	2		
3	3	SR Sensor signal valid – noisy	2	2		
4	3	SAL Sensor signal valid – noisy	3	2		
5	3	SAR Sensor signal valid – noisy	4	2		
2	4	SL Sensor shorted or open	1	4 or 5		Static Wheel Speed Sensor DTC. <i>Go to Section G, on Page 31.</i>
3	4	SR Sensor shorted or open	2	4 or 5		
4	4	SAL Sensor shorted or open	3	4 or 5		
5	4	SAR Sensor shorted or open	4	4 or 5		
2	5	SL Tire diameter out of range	1	13	<ul style="list-style-type: none"> • Verify correct tire size as desired. • Verify proper tire inflation. • Verify correct number of exciter ring teeth. • Verify that the Electronic Control Unit (ECU) has the proper tire size settings. 	
3	5	SR Tire diameter out of range	2	13		
4	5	SAL Tire diameter out of range	3	13		
5	5	SAR Tire diameter out of range	4	13		

Diagnostic Trouble Codes (DTCs) (continued)

1st Digit	2nd Digit	Diagnostic Trouble Code (DTC) Description	J1587 (SID)	J1587 (FMI)	Repair Information
4	6	SAL Sensor configuration error	3	13	<ul style="list-style-type: none"> Verify correct ABS configuration using blink codes or other diagnostic tools. If needed, reset to the default ABS configuration and power-up to initiate auto-configuration.
5	6	SAR Sensor configuration error	4	13	
POWER					
6	1	Over-voltage	251	3	<ul style="list-style-type: none"> Power supply diagnostic trouble code. <i>Go to Section F, page 30.</i>
6	2	Low-voltage	251	4	
6	3	Excessive power line resistance	251	13	
MODULATOR (MOD)					
7	1	MOD1 Hold solenoid shorted or open	42	3, 4, 5, 6 or 12	<ul style="list-style-type: none"> Clear DTCs. If DTCs return, replace the Bendix® TABS-6™ module.
7	2	MOD1 Release solenoid shorted or open	48	3, 4, 5, 6 or 12	
8	1	MOD2 Hold solenoid shorted or open	43	3, 4, 5, 6 or 12	Static ABS Modulator DTC. <i>Go to Section H, on Page 32.</i>
9	1	MOD3 Hold solenoid shorted or open	44		
8	2	MOD2 Release solenoid shorted or open	49		
9	2	MOD3 Release solenoid shorted	50		
7	3	MOD1 ABS modulator dynamic error	7	7	Dynamic ABS Modulator DTC. <i>Go to Section H, on Page 32.</i>
8	3	MOD2 ABS modulator dynamic error	8		
9	3	MOD3 ABS modulator dynamic error	9		
8	4	MOD2 Valve configuration error	8	13	<ul style="list-style-type: none"> Verify correct ABS configuration using blink codes or other diagnostic tools. If needed, reset to the default ABS configuration and power-up to initiate auto-configuration.
9	4	MOD3 Valve configuration error	9	13	
COMMON					
10	1	Valve MOD1/2 low-side switch shorted to ground	7	4	<ul style="list-style-type: none"> Check for corroded/damaged wiring or connectors between the ECU and MOD. At the MOD harness connector, verify: <ul style="list-style-type: none"> No continuity from modulator/AUX leads to ground. After repairs or if no issues found, then clear DTCs. If DTCs return, replace the Bendix® TABS-6™ module.
10	2	Valve MOD3 low-side switch shorted to ground	9		
10	3	ABS modulator dynamic error - all valves	7	7	Dynamic ABS Modulator DTC. <i>Go to Section H, on Page 32.</i>
10	4	Excessive ABS activity	1		Dynamic Wheel Speed Sensor DTC. <i>Go to Section G, on Page 31.</i>
ELECTRONIC CONTROL UNIT (ECU)					
11	1	ECU internal error	254	12	<ul style="list-style-type: none"> Check for damaged or corroded connectors. Check for damaged wiring. After repairs or if no issues found, then clear DTCs. If DTCs return, replace the Bendix TABS-6 module.
11	2	ECU configuration error	254	13	<ul style="list-style-type: none"> Verify correct ABS configuration using blink codes, PC-diagnostics or other off-board diagnostic tools. If needed, reset to the default ABS configuration and power-up to initiate auto-configuration.

Diagnostic Trouble Codes (DTCs) (continued)

1st Digit	2nd Digit	Diagnostic Trouble Code (DTC) Description	J1587 (SID)	J1587 (FMI)	Repair Information
J1587 DIAGNOSTIC					
12	1	J1587 diagnostics shorted or open	250	3, 4, 5, 6 or 12	<ul style="list-style-type: none"> • Check for corroded/damaged wiring or connectors between the ECU and J1587 Diagnostic. • Verify the following: <ul style="list-style-type: none"> - At the 18-pin ECU harness connector: <ul style="list-style-type: none"> (a) Continuity of the J1587 Diagnostic wiring to the lamp (auxiliary device). (b) +12V is not measured at J1587 Diagnostic lead. - At J1587 Diagnostic connector: <ul style="list-style-type: none"> (a) No continuity of the J1587 Diagnostic lead to ground. (b) No continuity from J1587 Diagnostic lead to any other ECU pin(s). (c) Replace/repair J1587 Diagnostic wiring or components as required.
TRAILER-MOUNTED ABS INDICATOR LAMP					
13	1	ABS lamp shorted or open	81	3, 4, 5, 6 or 12	<ul style="list-style-type: none"> • Check for corroded/damaged wiring or connectors between the ECU and ABS Indicator Lamp. • Verify the following: <ul style="list-style-type: none"> - At the five (5)-pin or 18-pin ECU harness connector: <ul style="list-style-type: none"> (a) Continuity of the ABS Indicator Lamp wiring to the lamp (auxiliary device). (b) +12V is not measured at ABS Indicator Lamp lead. - At ABS Indicator Lamp connector: <ul style="list-style-type: none"> (a) No continuity of the ABS Indicator Lamp lead to ground. (b) No continuity from ABS Indicator Lamp lead to any other ECU pin(s). (c) Replace/repair ABS Indicator Lamp wiring or components as required.
SERVICE INTERVAL					
14	1	Pad wear alert	70	1	Check pad wear. Perform service as needed.
14	2	Service interval	104	0	The service interval has expired. Perform the planned service, and then use Bendix® ACom® Diagnostic Software to reset the interval.

Troubleshooting: Using Hand-Held or PC-Based Diagnostic Tools

USING HAND-HELD OR PC-BASED DIAGNOSTICS

Troubleshooting and diagnostic trouble code clearing, as well as beginning a reconfiguration, may also be carried out using hand-held or PC-based diagnostic tools such as the Bendix® Trailer Remote Diagnostic Unit (TRDU™), Bendix® ACom® Diagnostic Software, or the ProLink™ tool.

BENDIX ABS DIAGNOSTIC TOOLS

Bendix® ACom® Diagnostic Software

Bendix ACom Diagnostic Software (version 6.5 or higher) is an RP-1210A compliant PC-based diagnostic software program that provides the highest level of diagnostic support for the Bendix® TABS-6™ module. With Bendix ACom Diagnostic Software, maintenance personnel can:

- Obtain Diagnostic Trouble Code (DTC) information (both active and inactive DTCs)
- Retrieve event history
- Clear inactive DTCs and event history
- Verify Electronic Control Unit (ECU) configuration
- Perform system and component tests
- Read/write customer information on scratch pads
- Save and print information
- Receive troubleshooting assistance

When diagnosing the Bendix TABS-6 module using a PC and Bendix ACom Diagnostic Software, the computer's USB port can be connected to the vehicle's diagnostic connector through an RP-1210A compliant PLC communications adapter.

For more information on the Bendix ACom Diagnostic Software, or RP-1210A compliant tools, contact Bendix or refer to your local authorized Bendix parts outlet.

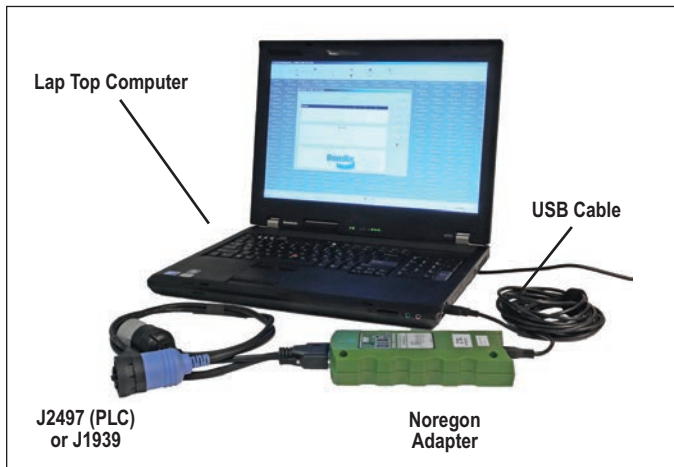

FIGURE 10 - LAP-TOP COMPUTER WITH BENDIX ACOM DIAGNOSTIC SOFTWARE



FIGURE 10 - THE BENDIX® TRAILER REMOTE DIAGNOSTIC UNIT (TRDU™)

Bendix Trailer Remote Diagnostic Unit (TRDU) Tool

The Bendix TRDU tool provides the technician with a visual indication of Antilock Braking System (ABS) component DTC information. The TRDU tool is specifically designed for use with Bendix Trailer ABS systems and Bendix makes no claims for its operation and/or usability with other brands of trailer ABS.

Features of the Bendix TRDU Tool

The TRDU tool attaches to a seven (7)-pin to seven (7)-pin adapter (See Figure 12) and then into the J560 of the towing vehicle. The TRDU tool communicates across PLC.

The TRDU tool allows the technician to:

- Troubleshoot ABS system component problems using Diagnostic Trouble Code reporting via LEDs.
- Reset Diagnostic Trouble Codes on Bendix® ABS Electronic Control Units (ECUs) by holding a magnet over the reset of the TRDU tool for less than six (6) seconds.
- Initiate a self-configuration event Mode used by Bendix ABS ECUs by holding a magnet over the reset area for greater than six (6) seconds but less than 11 seconds.

LED Diagnostic Trouble Codes			
VLT -	Power	MOD3 -	Modulator 3
ECU -	ABS Controller	LFT -	Left
SEN -	Wheel Speed Sensor	RHT -	Right
MOD1 -	Modulator 1	ADD -	Additional
MOD2 -	Modulator 2	ODO -	Odometer

Example: If the Diagnostic Trouble Code is "Right Additional Sensor", the TRDU™ tool will display one green and three red LEDs

LEDs
Green
VLT
Blue
ODO
All others are Red

FIGURE 11 - DIAGNOSTIC TROUBLE CODES



FIGURE 12 - THE BENDIX® TRDU™ TOOL AND ADAPTER

How the Bendix® Trailer Remote Diagnostic Unit (TRDU™) Tool Operates

When the TRDU tool is plugged into the adapter, and the adapter/TRDU tool is installed between the trailer connector and the J560 connector of the towing vehicle, all the LEDs will illuminate, and the green LED will flash four (4) times to indicate communications have been established.

If the ABS Electronic Control Unit (ECU) has no active Diagnostic Trouble Codes (DTCs), only the green LED will remain illuminated.

If the ABS ECU has at least one active DTC the TRDU tool displays the first DTC by illuminating the red LEDs, indicating the malfunctioning ABS component and its location on the vehicle. (See Figure 13.) If there are multiple DTCs on the ABS system, the TRDU tool will display one diagnostic trouble code first, then once that DTC has been repaired and cleared, the next code will be displayed.

The TRDU tool repeatedly blinks out the mileage stored once communications have been established. By counting the sequence of blinks and/or strobes on the blue LED the odometer reading is given. See *Odometer Function on page 8 for more details.*

- VLT (Flashing indicates either over- or under-voltage condition)

To pinpoint the root cause and to ensure the system diagnostic trouble code is properly corrected the first time, additional troubleshooting may be necessary.

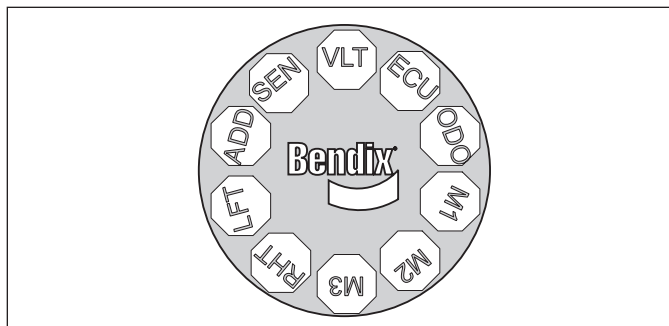

FIGURE 13 - BENDIX TRDU TOOL LED LOCATIONS

Bendix TRDU Tool Reset Function

The magnetic reset switch is located by the letter "B" in the Bendix logo on the top of the TRDU tool. Activation requires a magnet with 30 gauss minimum.

The reset operations are:

1. If the magnet is held over the switch for less than six (6) seconds the "clear diagnostic trouble codes" command is sent.
2. If the magnet is held over the switch for more than six (6) seconds, but less than 11 seconds, the Bendix® ABS "self-configuration command" is sent.

Additionally, it is recommended at the end of any inspection that the user switches off and restores the power to the ABS ECU, then check the ABS Indicator Lamp operation and TRDU tool to see if they indicate any remaining Diagnostic Trouble Codes.

MPSI Bendix Cartridge

MPSI provides a Bendix cartridge for use with the Pro-Link™ tool. For more information on the Bendix diagnostic cartridge from MPSI, contact Bendix or refer to your local authorized Bendix parts outlet.

PLC Diagnostic Tool

Diagnostic tools are available that detect the presence of a PLC signal and perform further system diagnostics directly on the power line. For more information on these diagnostic tools, contact Bendix or refer to your local authorized Bendix parts outlet.

CONTACTING BENDIX

www.Bendix.com

The Bendix on-line contacts directory will make it easy for you to find the Bendix resources you need. From this page, you can navigate to technical support contacts, service engineers, Bendix account managers, international contacts and more. Bendix.com is your complete Bendix resource.

Bendix Technical Assistance Team

For direct personal technical support, call the Bendix technical assistance team at:

1-800-AIR-BRAKE (1-800-247-2725),

Monday through Friday, 8:00 a.m. to 6:00 p.m. ET, and follow the instructions in the recorded message.

Alternatively, you may e-mail the Bendix Tech Team at: techteam@bendix.com.

To better serve you, please record the following information before you call the Bendix Tech Team, or include this information in your e-mail:

- Bendix product model number, part number and configuration.
- Vehicle make and model.

- Vehicle configuration. (Number of axles, tire size, etc.)
- System performance symptoms: When do they occur?
- What Diagnostic Trouble Codes (DTCs) have been identified using LEDs, blink codes or diagnostic tools?
- What troubleshooting/measurements have been performed?
- What Bendix service data literature do you have or need?

SERVICING THE BENDIX® TABS-6™ MODULE



All Bendix TABS-6 modules are initially defaulted to 2S/1M and may auto-configure to another ABS configuration if additional sensors and/or ABS modulators are detected. An incorrect ABS configuration may cause DTC indication or degraded ABS performance. Before and after activating a self-configuration, always check the current ABS configuration by using blink code diagnostics or a diagnostic tool.

Prior to performing service to the Bendix TABS-6 module, always perform the following steps:

1. Follow all General Safety Guidelines including, but not limited to, those on page two (2) of this document.
2. Turn power off.
3. Drain the air pressure from all reservoirs.
4. Remove as much contamination as possible prior to disconnecting electrical connections and air hoses.
5. Note the Bendix TABS-6 module's mounting position on the vehicle.

REMOVING THE BENDIX TABS-6 MODULE

1. Open the cover by sliding the locking tab to the left. Retain the cover.
2. Disconnect the five (5)- or 18-pin Electronic Control Unit (ECU) connector and the two (2)-pin wheel speed sensor connectors.
3. Mark for reinstallation and then remove all air hoses and plugs connected to the module.
4. Remove the module from the vehicle by removing the mounting fasteners or by rotating the entire assembly counter-clockwise from the tank mount.

SERVICING THE CONTROL PORT FILTER

The Bendix TABS-6 module has an in-line filter in the control port (See *Figure 1*). This filter should be inspected and cleaned (if any contamination is found), every four months, 34,000 miles or 1,200 operating hours. For severe applications, this inspection interval may be reduced. If the filter is found to be damaged, install a replacement. The filter should also be inspected as part of any troubleshooting where the service brakes are slow to apply and other possible causes have been ruled out.

SERVICE REPLACEMENT OF OTHER ABS CONTROLLERS

The Bendix TABS-6 module is designed to be used as the service replacement part for the Bendix® MC-12™, MC-30™ and A-18™ trailer ABS controllers. When controller service replacement parts are required, a Bendix TABS-6 module and pigtail harness must replace the entire Bendix MC-12, MC-30 or A-18 controller assembly and pigtail harness. When replacing a Bendix® MCE-12™ controller, the integral emergency function (Bendix® EV-2™ valve) must be replaced by a Bendix® DC-4® and TR-3™ valve combination. See *pages 20-23 for plumbing details*. Bendix TABS-6 module kits are available to replace Bendix MC-12, MC-30 and A-18 controller assemblies and harnesses. For more information, contact Bendix or your local authorized Bendix parts outlet.

1. Disconnect the power connector and wheel speed sensors from the Bendix MC-12, MC-30 or A-18 controller pigtail harness.
2. Remove all air hoses and plugs connected to the unit.
3. Remove the Bendix MC-12, MC-30 or A-18 controller assembly and pigtail from the vehicle by removing the mounting bracket nuts or by rotating the entire assembly counter clockwise from the tank nipple mount.
4. Install the new pigtail, starting at the power connector and properly securing the harness every 18 inches to the ECU location.
5. Next, refer to the Reinstallation of the Bendix TABS-6 module section.

REINSTALLATION OF THE BENDIX TABS-6 MODULE



All Bendix TABS-6 module service replacement parts are initially defaulted to 2S/1M and may auto-configure to another ABS configuration if additional sensors and/or ABS modulators are detected. An incorrect ABS configuration may cause DTC indication or degraded ABS performance. Before and after activating a self-configuration, always determine the current ABS configuration by activating blink code diagnostics.

Inspect the original mounting hardware: If it is in good condition, it can be reused for installation. If replacement hardware is needed, use grade-5 3/8-18 bolts, nuts and lock washers for the frame-mount unit, or a schedule 80 (heavy gauge steel) 3/4" nipple for the tank-mount unit.

Inspect the location selected for installation and clean as necessary.

NOTE: Inspect all components, including the replacement trailer ABS module, for any external damage, such as cracked valve ports, electronic housings, etc. Any components found to be damaged should not be installed on the vehicle and must be replaced.

1. Position and secure the unit in the original mounting orientation (the exhaust port must point straight down):
For tank-mount modules: Install the nipple fitting into the modulator-valve supply port. Then rotate the entire assembly into the tank port until secure. Over-torquing of the tank nipple could cause damage to the valve body.
For frame-mount modules: Torque the mounting nuts to 180-220 in-lbs.
2. Reconnect all air hoses and plugs to the module. Depending on the installation, additional plugs may be necessary. Make certain that no thread sealing material enters the valve. All air hoses and fittings should be checked for leaks prior to returning the vehicle to service.
3. Reconnect the Electronic Control Unit (ECU) and wheel speed sensor electrical connectors to the unit. Apply a moderate amount of non-conductive electrical grease to each connector pin before reconnecting.
4. The new Bendix® TABS-6™ module may need to be reconfigured for proper operation. See *Auto-Configuration, on page 8*.
5. Leakage and Operational Tests must be performed before returning the vehicle to service.

LEAKAGE AND OPERATIONAL TESTS



For all NPT fittings use of a thread sealant is required. For NPTF fittings the use of a thread sealant is recommended, this can be a pre-applied or a hand-applied sealant product (with PTFE). When using a hand applied sealant, use caution so as not to over-apply. Always follow the fitting manufacturer's pre-applied or hand-applied thread sealant recommendations. Use of PTFE tape is not approved and will void the Bendix ABS/TRSP valve warranty.

1. Before performing leak tests, block the wheels.
2. Fully charge the air brake system and verify proper brake adjustment.
3. Make several trailer brake applications and check for prompt application and release at each wheel.
4. Check the module, modulator valve(s) and all air hose fittings for leakage using a soap solution:
Check the ABS solenoid body with the trailer service brakes fully applied. If leakage is excessive, more than a one (1) inch bubble within one (1) minute, replace the module.
Check the relay exhaust port with the trailer service brakes released to be sure that leakage is less than a single 1" bubble within three (3) seconds. If excessive leakage is detected at the relay exhaust port, perform the following test before replacing the module:
 - Apply the trailer spring brakes. Recheck for leakage around the relay exhaust port. If the exhaust port stops leaking, this indicates a leak between the emergency and service sides of the spring brake chamber. However, if the relay exhaust port continues to leak excessively, replace the Bendix TABS-6 module.
5. Apply power and monitor the power-up sequence to verify proper system operation. See *page 7*.
6. Determine the current ABS configuration by activating blink code diagnostics or using a diagnostic tool. If necessary, reset the ABS configuration and allow the module to auto-configure. See *page 8*.
7. Calibrate and set odometer parameters if necessary using a diagnostic tool. Refer to the *Odometer Function section on page 8*.
8. Where a safe location (e.g. restricted access area or test track) is available, it is possible to road test the ABS function by making an abrupt stop from a vehicle speed of about 20 MPH to check for proper function. The wheels should not enter a prolonged lock condition and ABS function should be audible. It is the responsibility of the technician to perform this test in a safe location.

ABS WIRING

WARNING

Disconnect the electrical connectors from the ABS/TRSP Controller before welding on the trailer.

WARNING

Dielectric grease should be applied to electrical connectors to help protect against moisture intrusion.

All connector leads of the Bendix TABS-6 module pigtail harness are weather sealed at the connector interface and are clearly labeled for proper installation.

Bendix provides over-molded versions of the Bendix TABS-6 wiring harness and Bendix recommends that the complete harness be replaced if corrosion or damage occurs.

When troubleshooting ABS wiring, some general rules should be followed where applicable.

1. Check all wiring and connectors to ensure they are secure and free from visible damage (e.g. cuts, abrasions, etc.).
2. Check for evidence of wire chafing due to poor routing, or poor securing, of wires.
3. Check connectors for proper insertion and locking.
4. Verify that the connector pins are properly greased with a non-conductive electrical grease compound.
5. Connector terminals must not show signs of corrosion or exposure to the environment.
6. Never pierce wire insulation when checking for continuity.
7. Do not deform individual pins or sockets during probing with a volt/ohm meter.
8. It is strongly recommended to properly secure all wiring harness and sensor leads at least every 18 inches.
9. Apply a moderate amount of non-conductive electrical grease to each connector pin before reconnecting.

MISCELLANEOUS MAINTENANCE

WARNING



GLAD HAND MAINTENANCE

▲ **NEVER POUR ANY LIQUIDS** (alcohol, anti-freeze, additives, etc.) into the glad hands. Liquids may cause the o-rings and seals to swell, may result in lubrication loss and leave harmful residues.

- ▲ Prevent nesting insects and contaminants from entering and blocking the air hoses. Check that screens are present and clean.
- ▲ Drain the trailer air tanks a minimum of every six (6) months.

Liquids/Contamination can cause **TRAILER AIR BRAKE FAILURE** and/or the **INABILITY TO RELEASE** the trailer parking brakes.

WARNING

BENDIX® ABS SYSTEM POWER-UP CHECK

At power-up the trailer ABS indicator lamp should briefly illuminate “ON” as a bulb check.

If the indicator lamp does not illuminate at power-up, the ABS system may not be powered, or the bulb may need to be replaced. Service the trailer ABS system.

- ▲ If the lamp remains “ON” after power-up there may be active Diagnostic Trouble Codes. Service the trailer ABS system. (To ensure full ABS/TRSP functionality, service as soon as possible.)

Other Important Practices:

- ▲ Follow all standard industry safety practices.
- ▲ Sealant for ABS Fittings: Use pre- or hand-applied; Never PTFE tape (Voids Bendix ABS Warranty).
- ▲ Use open-ended clips (never cable ties) to hold sensor leads to jounce lines.
- ▲ Drain the trailer air tanks a minimum of every six (6) months.
- ▲ Disconnect the electrical connectors from the ABS Controller when welding on the trailer.

Troubleshooting: Electrical Schematics

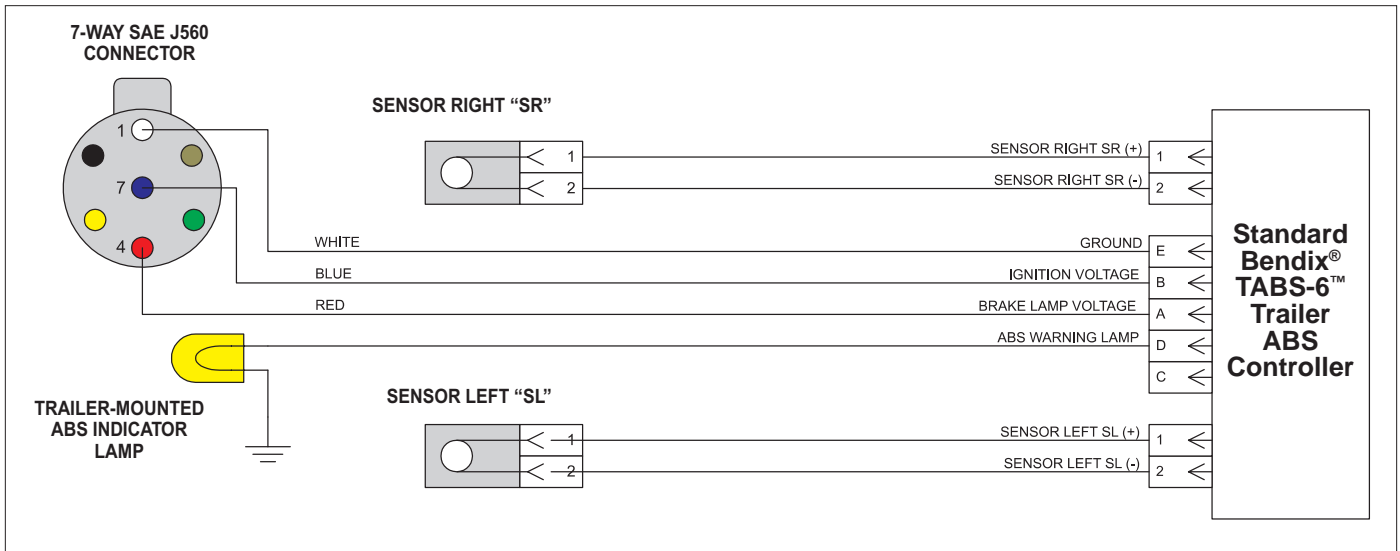

FIGURE 15 - ELECTRICAL SCHEMATIC - 2S/1M FOR STANDARD BENDIX® TABS-6™ MODULE WITH FIVE (5)-PIN ELECTRONIC CONTROL UNIT (ECU) CONNECTOR

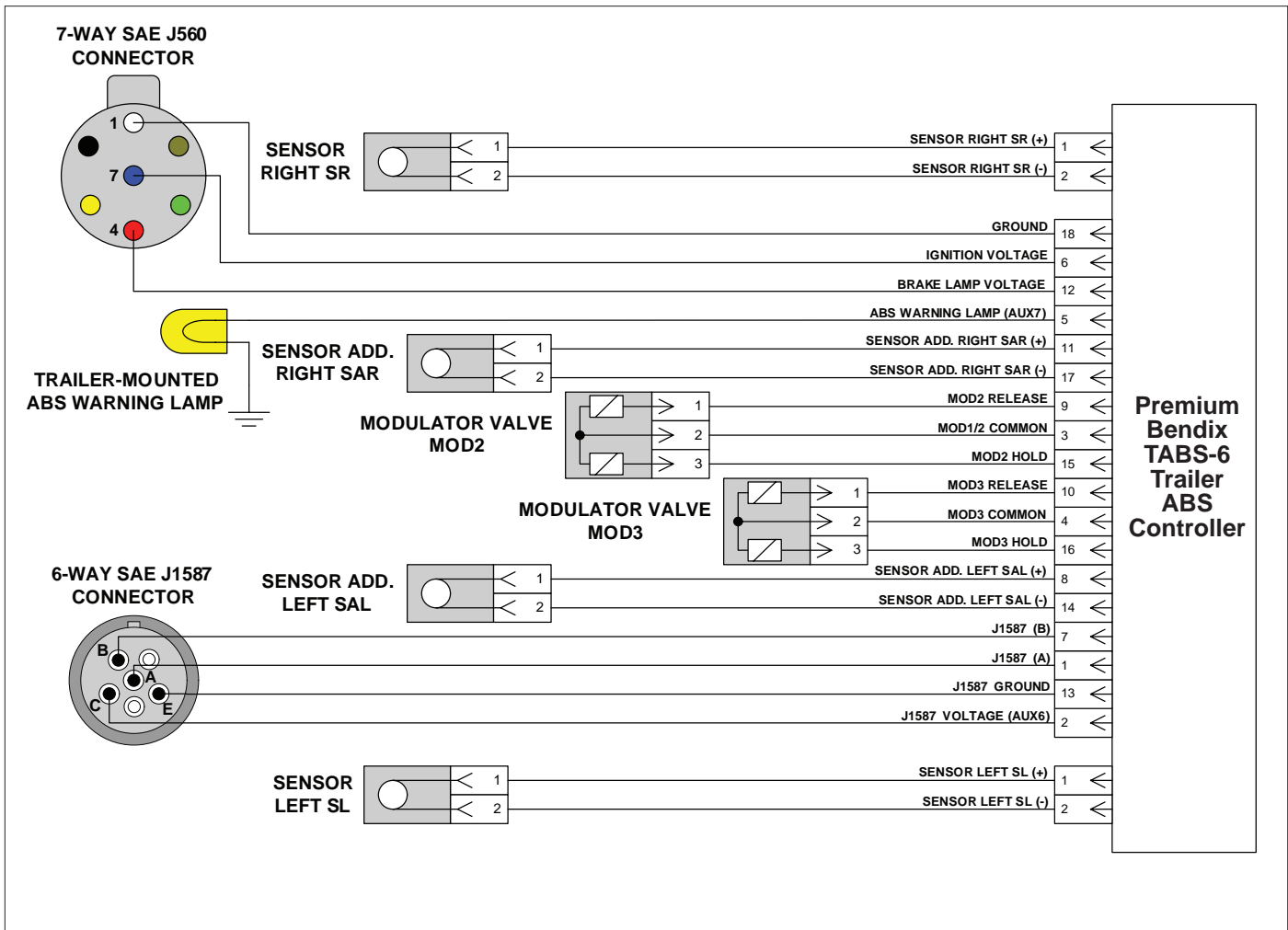
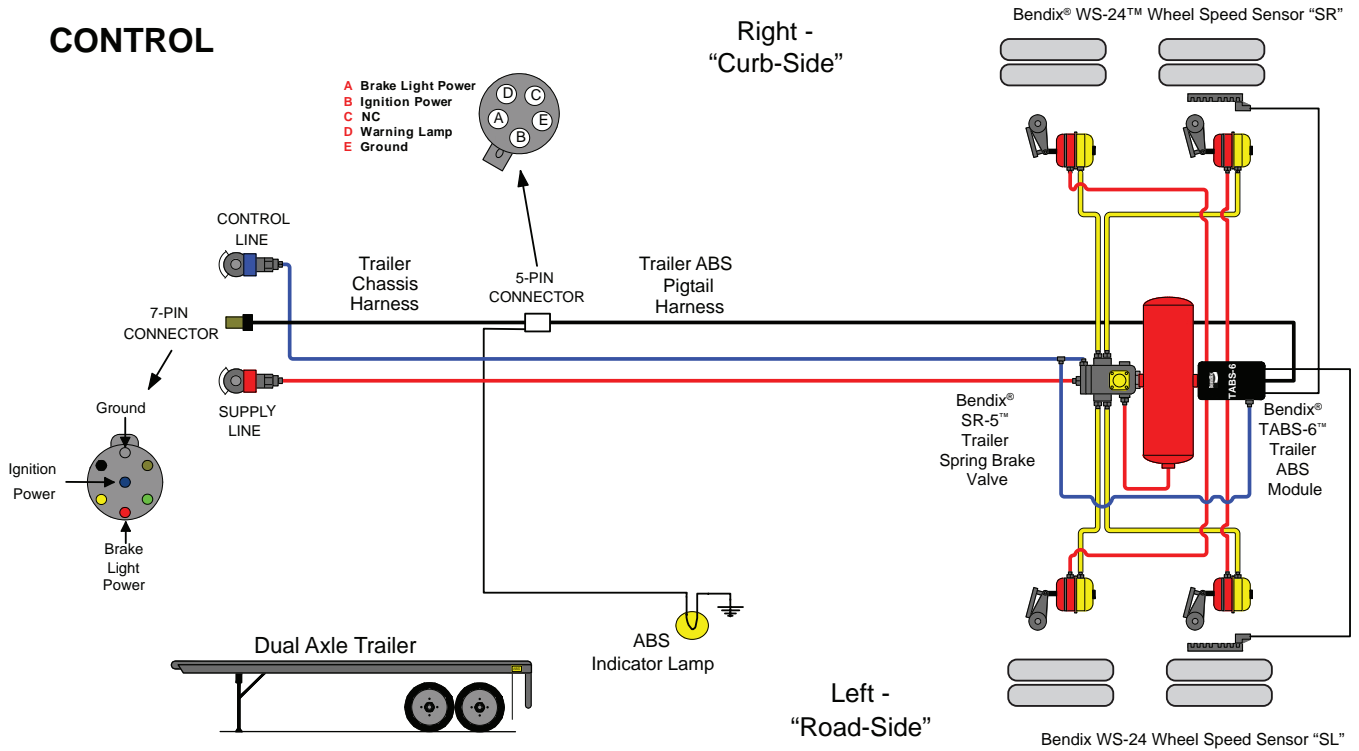

FIGURE 16 - PREMIUM BENDIX TABS-6 MODULE (18-PIN ECU CONNECTOR) ELECTRICAL SCHEMATIC - 4S/3M

Troubleshooting: System Schematics

2S/1M - AXLE CONTROL



2S/1M - DOLLY AXLE CONTROL

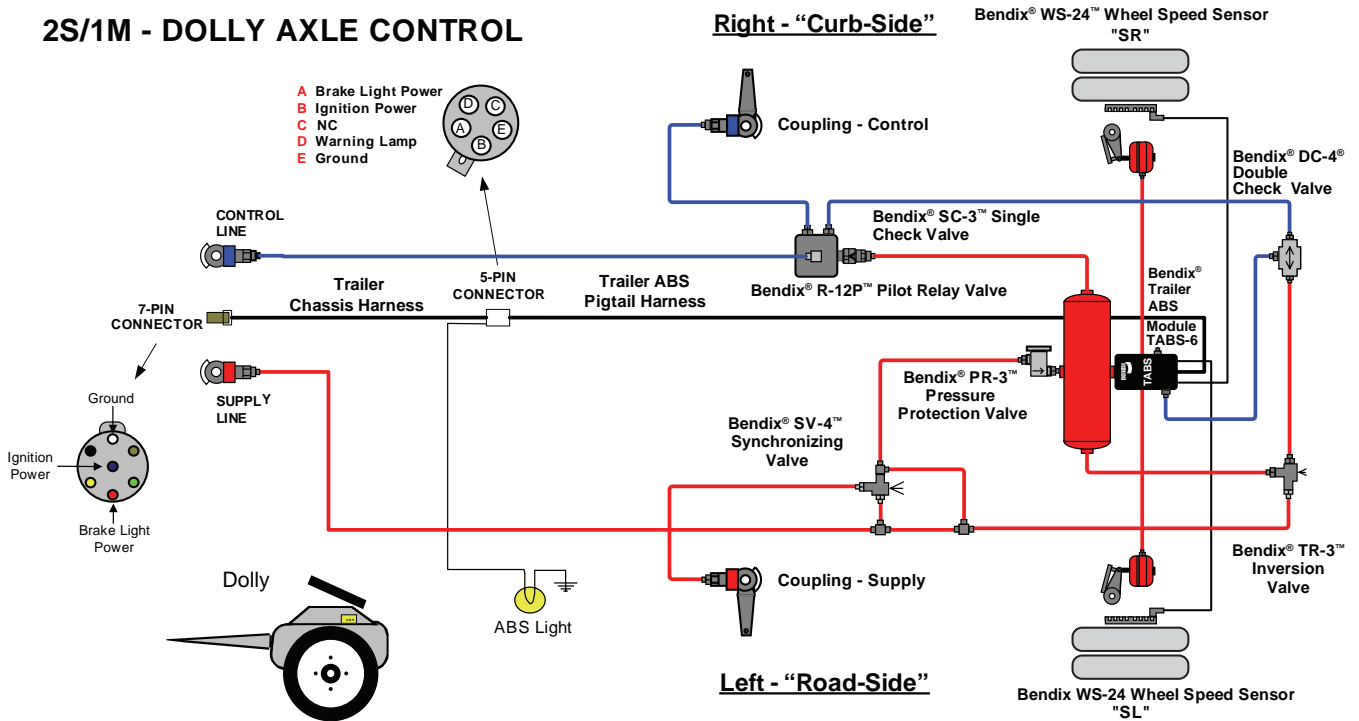

Troubleshooting: System Schematics (continued)

2S/2M - AXLE CONTROL

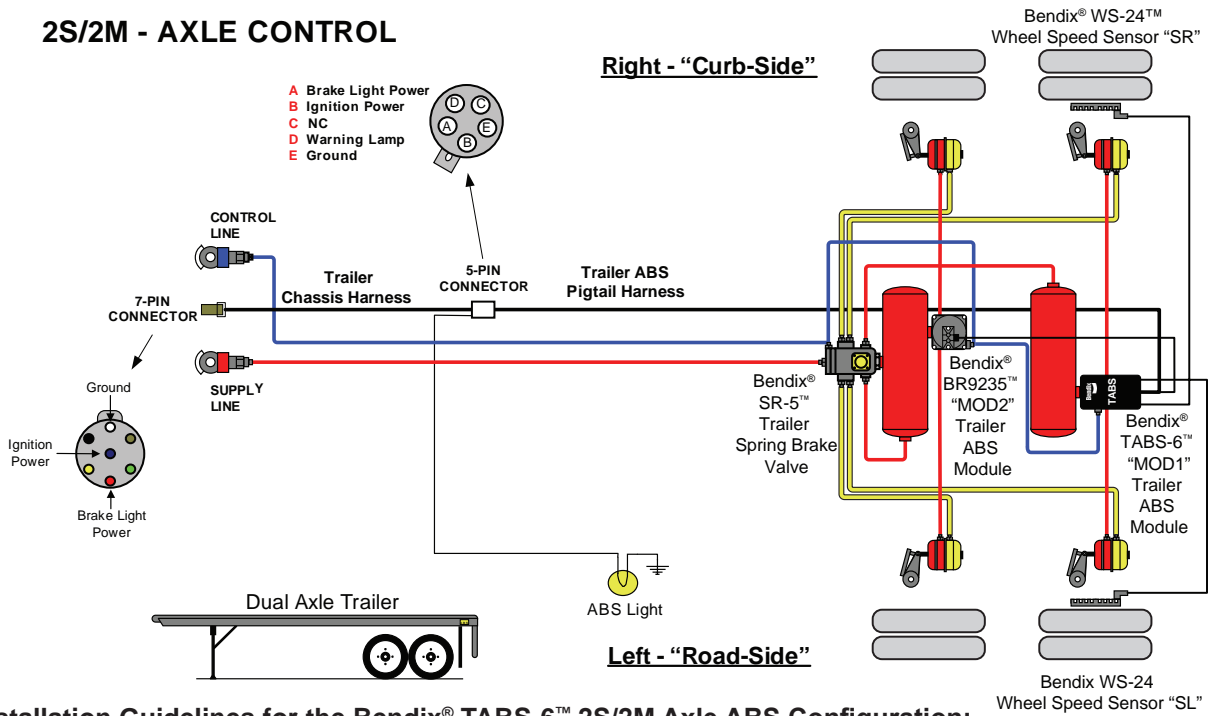

Installation Guidelines for the Bendix® TABS-6™ 2S/2M Axle ABS Configuration:

- MOD1 (Bendix TABS-6 ABS Unit) controls the wheel(s) of a primary axle(s).
- MOD2 (Bendix BR9235™ Modulator Unit) controls the wheels of an additional axle(s).
- SL & SR (Primary Sensors) senses wheels on the primary axle (always on ground) that MOD1 controls.
- For lift axle applications, MOD2 controls the wheels for the lift-able axle

2S/2M - SIDE CONTROL

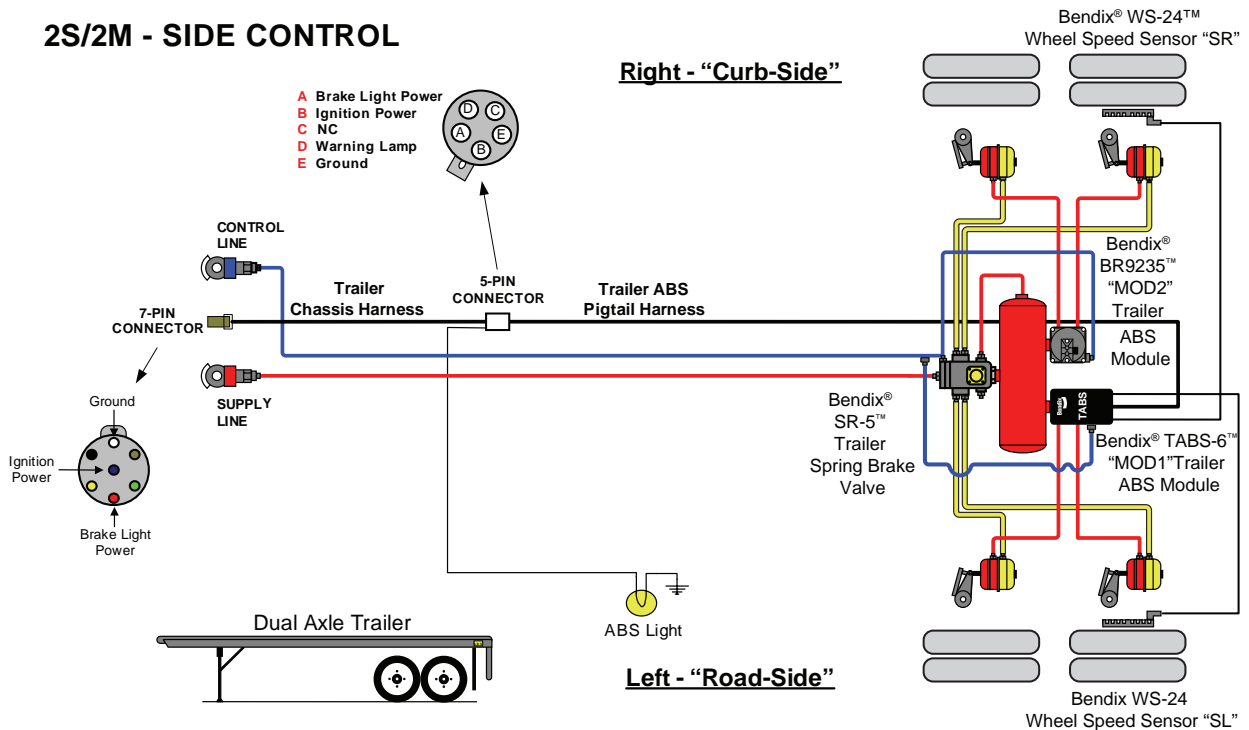

Installation Guidelines for the Bendix TABS-6 2S/2M Side ABS Configuration:

- MOD1 (Bendix TABS-6 ABS Unit) controls the left "road-side" wheel(s) of a primary axle(s).
- MOD2 (Bendix BR9235 Modulator Unit) controls the right "curb-side" wheel(s) of a primary axle(s).
- For lift axle applications, SL & SR (Primary Sensors) senses the wheels of the stationary, non lift-able axle

Troubleshooting: System Schematics (continued)

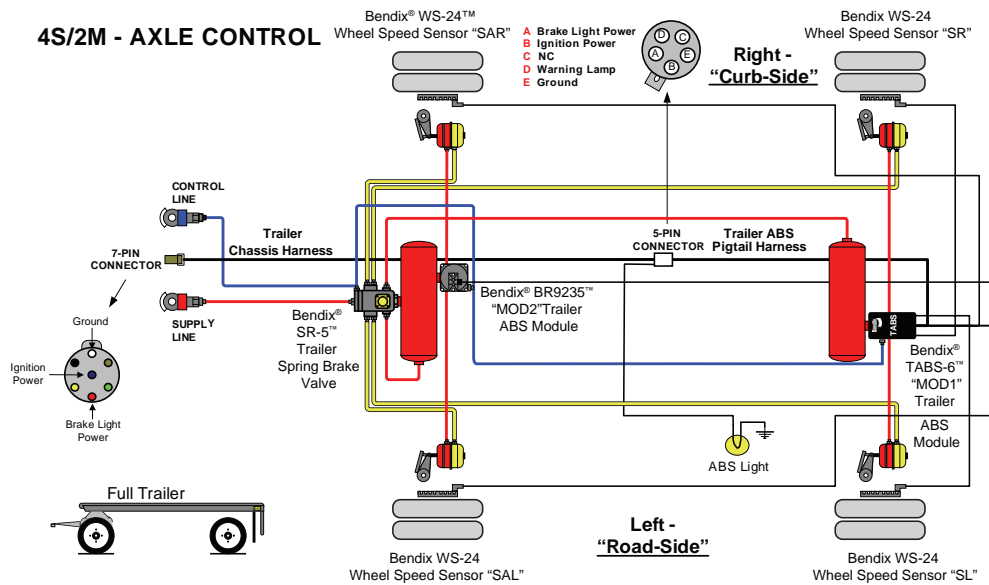

Installation Guidelines for the Bendix® TABS-6™ 4S/2M Axle ABS Configuration:

- MOD1 (Bendix TABS-6 ABS Unit) controls the wheel(s) of a primary axle(s).
- MOD2 (Bendix® BR9235™ Modulator Unit) controls the wheels of an additional axle(s).
- SL & SR (Primary Sensors) senses wheels on the primary axle (always on the ground) that MOD1 controls, and are connected to the dedicated two (2)-pin connector on the Bendix TABS-6 module.
- SAL & SAR (Additional Sensors) senses the wheels that MOD2 controls, and are connected to the 18-pin connector on the Bendix TABS-6 module.
- For lift axle applications, MOD2 controls the wheels for the lift-able axle

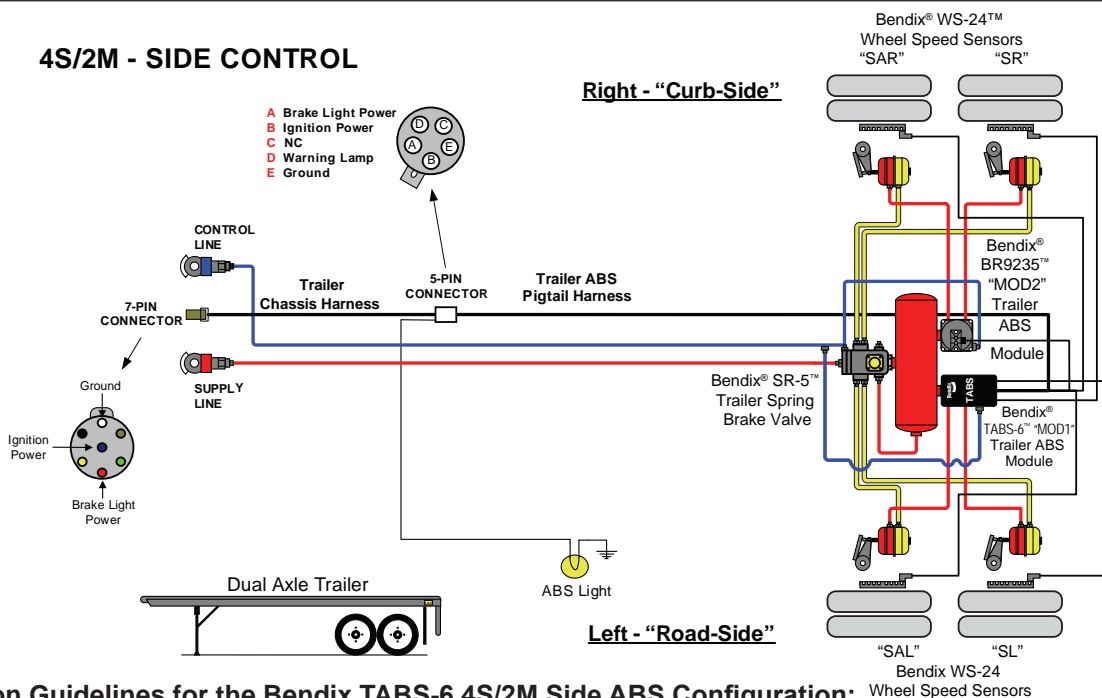

Installation Guidelines for the Bendix TABS-6 4S/2M Side ABS Configuration:

- MOD1 (Bendix TABS-6 ABS Unit) controls the left "road-side" wheel(s) of a primary axle(s).
- MOD2 (Bendix BR9235 Modulator Unit) controls the right "curb-side" wheel(s) of a primary axle(s).
- SL & SR (Primary Sensors) are connected to the dedicated two (2)-pin connector on the Bendix TABS-6 module.
- SAL & SAR (Additional Sensors) are connected to the 18-pin connector on the Bendix TABS-6 module.
- For lift axle applications, SAL & SAR (Additional Sensors) senses the wheels of the lift-able axle.

Troubleshooting: System Schematics (continued)

4S/3M - SIDE/AXLE CONTROL

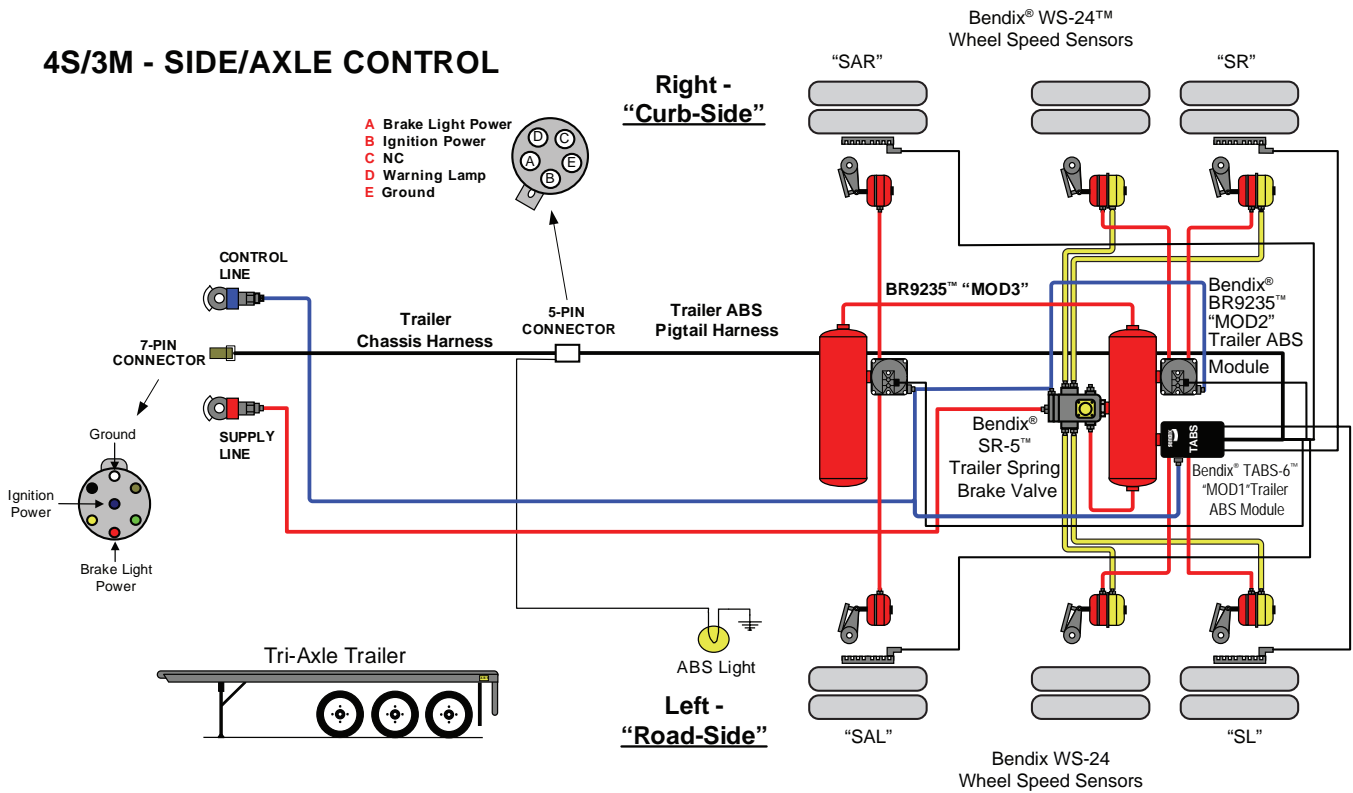

Installation Guidelines for the Bendix® TABS-6™ 4S/3M Side/Axle ABS Configuration:

- MOD1 (Bendix TABS-6 ABS Unit) controls the left "road-side" wheel(s) of a primary axle(s).
- MOD2 (Bendix® BR9235™ Modulator Unit) controls the right "curb-side" wheel(s) of a primary axle(s).
- MOD3 (Bendix BR9235 Modulator Unit) controls the wheels of an additional axle(s).
- SL & SR (Primary Sensors) senses wheels on the primary axle (always on the ground) that MOD1 controls, and are connected to the dedicated two (2)-pin connector on the Bendix TABS-6 module.
- SAL & SAR (Additional Sensors) senses the wheels that MOD3 controls, and are connected to the 18-pin connector on the Bendix TABS-6 module.
- For lift axle applications, MOD3 controls the wheels for the lift-able axle.

Troubleshooting Flowcharts

Diagnostic trouble code information can be retrieved from the Bendix® TABS-6™ module by using blink code diagnostics, or a diagnostic tool. The following troubleshooting flow charts will help the technician isolate the cause of the Diagnostic Trouble Code (DTC) and confirm whether the DTC resides in the component, wiring or connectors.

Troubleshooting should always begin by observing the dash or trailer-mounted ABS indicator lamp during the Bendix TABS-6 module's power-up sequence. If it is necessary to make electrical measurements, always begin by making measurements of the voltage and resistance at the five (5)- or 18-pin ECU pigtail harness connector.

Once the circuit DTC is found, isolate the area needing repair by repeating the measurements at all connections in the affected circuit towards the modulator, wheel speed sensor, etc.

No voltage or resistance measurements are to be made on the bulkhead connector pins of the module.

Troubleshooting Flowcharts

Section A : (Power-Up Sequence)	
Trailer-Mounted ABS Indicator Lamp	Page 25
Section B: (Power-Up Sequence)	
Dash-Mounted ABS Indicator Lamp	Page 26
Section C: Diagnostic Trouble Code (DTC) Blink	
Code Quick Reference	Page 27
Section D: Diagnostic Trouble Code	
Trailer Remote Diagnostic Unit (RDU™) Tool	
LED Quick Reference	Page 28
Section E: Troubleshooting the Trailer-Mounted	
ABS Indicator Lamp Circuitry	Page 29
Section F: Troubleshooting the Power Supply	Page 30
Section G: Troubleshooting the Bendix® WS-24™ Wheel	
Speed Sensors	Page 31
Section H: Troubleshooting the Bendix® BR9235™ Modulator	
Relay Valves.	Page 32

**SECTION A: (POWER-UP SEQUENCE)
TRAILER-MOUNTED ABS INDICATOR LAMP**

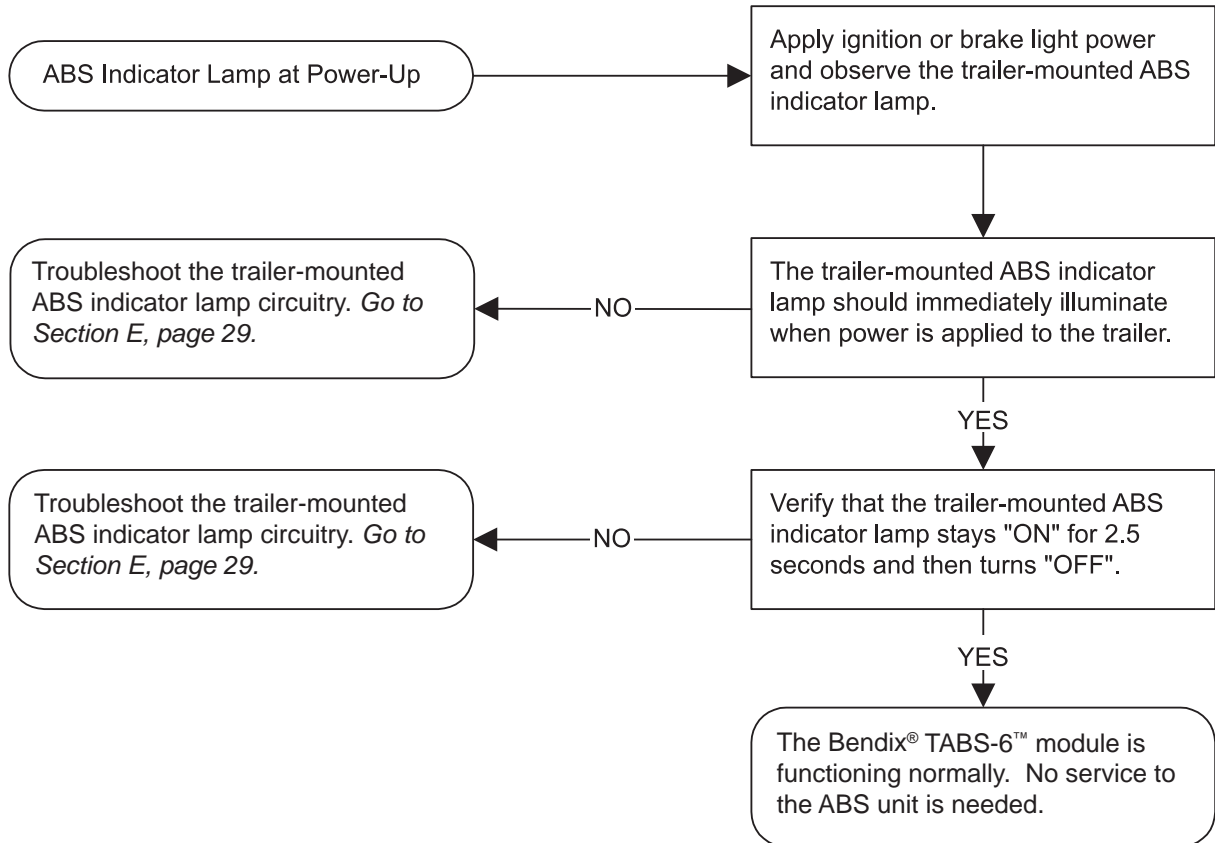

SECTION B: (POWER-UP SEQUENCE) DASH-MOUNTED ABS INDICATOR LAMP

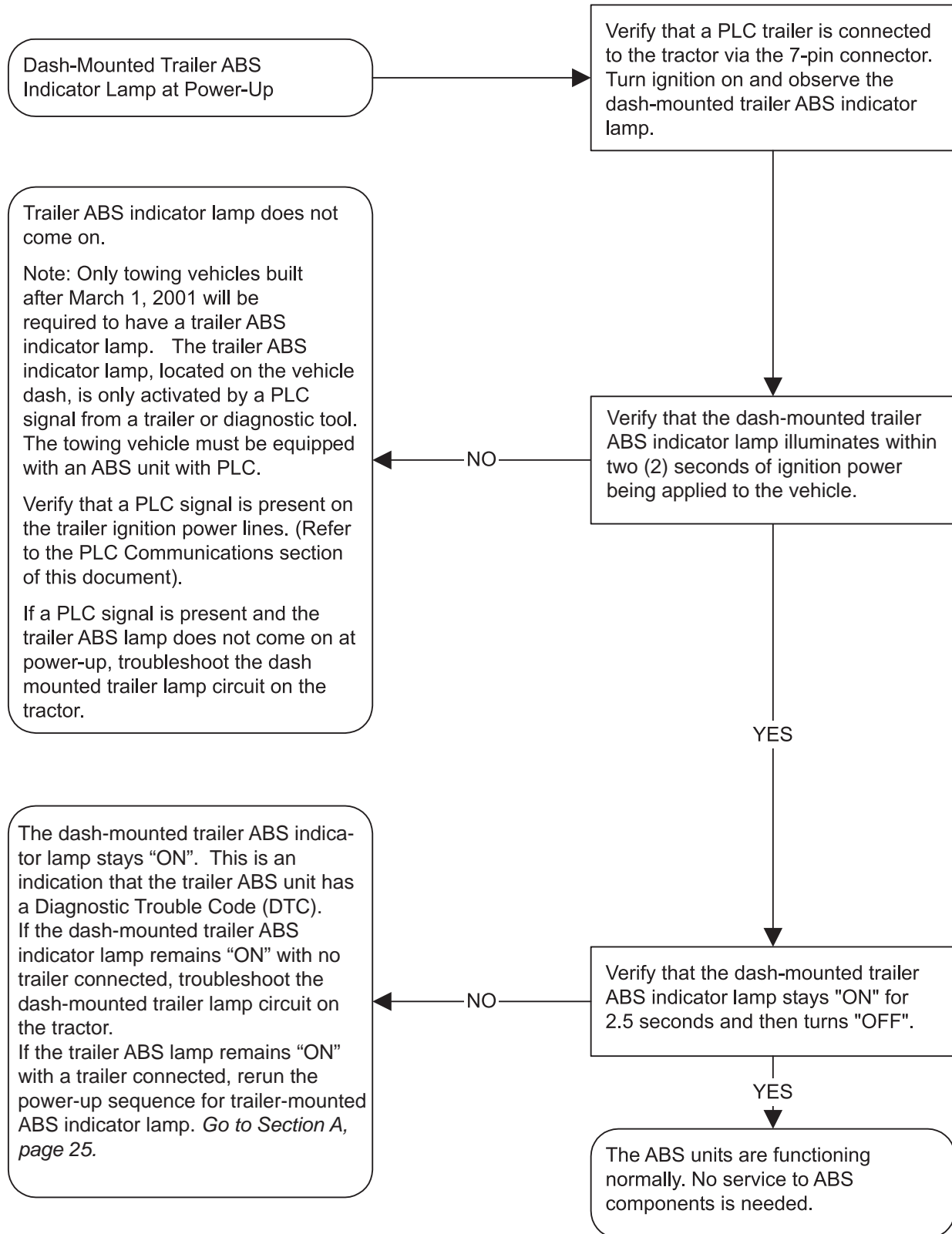

SECTION C: DIAGNOSTIC TROUBLE CODE (DTC) BLINK CODE QUICK REFERENCE

1st Blink Code		2nd Blink Code		Repair Information
Code	Location	Code	Description	
1	All	1	No Diagnostic Trouble Codes (DTCs)	• System fully operational - no DTCs detected
2	Sensor SL	1	Sensor signal invalid - large air gap	• Go to Section G - Dynamic Wheel Speed Sensor (WSS) DTCs
3	Sensor SR	2	Sensor signal invalid - loss of signal	• Go to Section G - Dynamic WSS DTCs
4	Sensor SAL	3	Sensor signal invalid - noisy	• Go to Section G - Dynamic WSS DTCs
5	Sensor SAR	4	Sensor shorted or open	• Go to Section G - Static WSS DTCs
		5	Tire diameter out of range	• Verify correct tire size, proper tire inflation & correct number of exciter ring teeth. Verify that the Electronic Control Unit (ECU) has the proper tire size settings.
		6	Sensor configuration error	• Verify correct ABS configuration. If needed, reset to the default ABS configuration and power-up to initiate auto-configuration.
6	Power	1	Over-voltage	• Go to Section F - Power Supply
		2	Low-voltage	• Go to Section F - Power Supply
		3	Excessive power line resistance	• Go to Section F - Power Supply
7	Valve MOD1	1	Hold solenoid (AUX) shorted or open	• Go to Section H - ABS Modulator DTCs
8	Valve MOD2	2	Release solenoid (AUX) shorted or open	• Go to Section H - ABS Modulator DTCs
9	Valve MOD3	3	ABS modulator dynamic error	• Go to Section H - ABS Modulator DTCs
		4	Valve configuration error	• Verify correct ABS configuration. If needed, reset to the default ABS configuration and power-up to initiate auto-configuration.
10	Common	1	Valve MOD1/2 low-side switch shorted to ground	• Go to Section H - ABS Modulator DTCs
		2	Valve MOD3 (AUX) low-side switch shorted to ground	• Go to Section H - ABS Modulator DTCs
		3	ABS modulator dynamic error - all valves	• Go to Section H - ABS Modulator DTCs
		4	Excessive ABS activity	• Go to Section G - Dynamic WSS DTCs
11	ECU	1	ECU internal error	• Check for damaged or corroded connectors. Check for damaged wiring. After repairs or if no issues found, then clear DTCs. If DTCs return, replace the module.
		2	ECU configuration error	• Verify correct ABS configuration. If needed, reset to the default ABS configuration and power-up to initiate auto-configuration.
12	Diagnostics	1	J1587 diagnostics (AUX6) shorted or open	• Check for corroded/damaged wiring or connectors between the ECU and J1587 Diagnostic (AUX6). Replace/repair J1587 Diagnostic (AUX6) wiring or components as required.
13	Indicator Lamp	1	ABS lamp (AUX7) shorted or open	• Go to Section E - Trailer ABS Indicator Lamp

To Read/Clear Diagnostic Troubleshooting Codes (DTCs):

1. Apply constant power to the trailer (ignition switch).
2. Within 15 seconds, apply/release the brake pedal at 1 second intervals:
 - (a) 3 times for displaying Active DTCs.
 - (b) 4 times for displaying Inactive DTCs.
 - (c) 5 times for clearing Active DTCs.
3. After 5 seconds delay, the blink codes will be displayed.
4. Observe the trailer-mounted ABS indicator lamp and record blink code(s).
5. Refer to blink code chart for description.
6. After making repairs and clearing Active DTCs, verify lamp is no longer illuminated.

SECTION D: DIAGNOSTIC TROUBLE CODE (DTC) BENDIX® TRDU™ TOOL LED QUICK REFERENCE

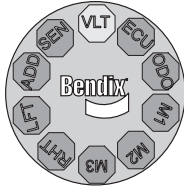

Power

System OK - A solid green VLT LED indicates proper voltage is reaching the module. If no red LEDs are on, then no DTC's are detected.

If the ABS indicator lamp is on with no red LEDs, Go To Section E, page 29.

Voltage Out of Range - A flashing green VLT LED indicates ECU voltage below 8.0 VDC or above 16.0 VDC. The VLT LED will flash until power is brought into normal range. Go to Section F, page 30.

No Voltage - When the VLT LED is off, the module is receiving very low or no voltage, or there is no communication to TRDU. The ECU LED may be on in this case. Go to Section F, page 30.

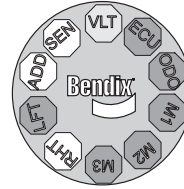

Wheel Speed Sensor DTC

The red SEN LED is on to indicate a DTC with a wheel speed sensor. The example above shows the LEDs illuminated when there is an additional right sensor (SAR) DTC.

Troubleshooting and repair are the same for a DTC on any wheel speed sensor. The indicated sensor DTC may be static or dynamic.

Static DTCs are related to wiring or component failures such as open or short circuits.

Dynamic DTCs are related to abnormal wheel speed signals or behaviors. Go To Section G, page 31.

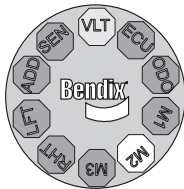

ABS Modulator DTC

The red M1, M2 and/or M3 LED is on to indicate a DTC with an ABS modulator. The example above shows the LEDs illuminated when there is a DTC for a second ABS modulator (MOD2).

The indicated modulator DTC may be static or dynamic.

Static DTCs are related to wiring or component failures such as open or short circuits.

Dynamic modulator DTCs are related to abnormal wheel speed behaviors during ABS.

Go to Section H, page 32.

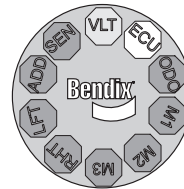

ECU DTC

The red ECU LED is on to indicate a DTC internal to the TABS-6 module. Reset the TRDU™ tool with a magnet. If the DTC returns, replace the module.

If the red ECU LED is on and the green VLT LED is off, the module may have very low voltage. In this case, go to Section F, page 30.

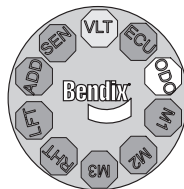

Odometer Mileage - The TRDU will continuously display the odometer information (x1000) by flashing the blue ODO LED. There will be a 20 second pause between ODO displays.

As an example: 152,431 miles will be displayed as:

152 (x1000) ... or 1 blink (pause), 5 blinks (pause), 2 blinks.

Zeros are displayed by the blue ODO LED strobing twice.

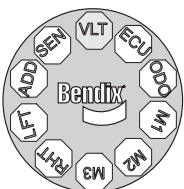

Magnetic Reset - All LEDs will be on while a magnet is held in place at the RESET location near the "B" in Bendix. When held for less than 6 seconds, the DTCs are cleared. When held for more than 6 seconds, the ABS configuration is reset. If one or more LEDs do not illuminate, replace the TRDU™ tool. Do not reset the DTC codes until troubleshooting of the indicated component is complete.

SECTION E: TROUBLESHOOTING THE TRAILER-MOUNTED ABS INDICATOR LAMP CIRCUITRY

Trailer-mounted ABS indicator lamp did not illuminate during the power-up sequence.

Troubleshoot the power supply to the module. *Go to Section F, page 30.*
Continue if the power and ground wiring are OK.

Turn off the power to the module. Inspect the condition of the ABS indicator lamp, connector and ground. Using a volt/ohm meter, verify continuity across the bulb. Verify continuity from the trailer chassis ground to the ABS indicator lamp ground pin.
If repairs are made, rerun the power-up sequence. *Go to Section A, page 25.*
Continue if the indicator lamp and ground wire check out OK

With power off to the module, disconnect the 5 or 18-pin ECU connector.
Verify continuity from ABS WL pin of the Electronic Control Unit (ECU) connector and the ABS indicator lamp connector.
If repairs are made, rerun the power-up sequence. *Go to Section A, page 25.*
If condition still exists, replace the module.

Trailer-mounted ABS indicator lamp remains "ON" during the power-up sequence.

Determine if a module Diagnostic Troubleshooting Code (DTC) exists using any of the following methods:

- TABS-6 Blink Code Diagnostics. *Go to Section C, page 27.*
- Trailer Remote Diagnostic Unit *Go to Section D, page 28.*
- Hand-held or PC-diagnostic tools.

If DTC(s) exist and repairs are made, rerun the power-up sequence. *Go to Section A, page 25.*
Continue if no DTCs are found and the ABS module appears to be functioning normally.

With power off to the module, disconnect the 5- or 18-pin ECU connector.
Using a volt meter, verify that there is not a short to Vbat, between the ABS WL pin of the ECU connector and the ABS indicator lamp connector.
If repairs are made, rerun the power-up sequence. *Go to Section A, page 25.*
If condition still exists, replace the module.

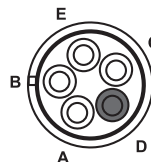

Looking into Standard Bendix® TABS-6™ Module Wire Harness (Pin D ABS Indicator Lamp)

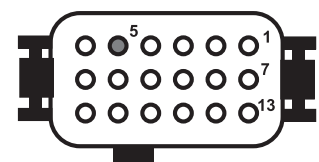

Looking into Premium Bendix TABS-6 Module Wire Harness (Pin 5 ABS Indicator Lamp)

SECTION F: TROUBLESHOOTING THE POWER SUPPLY

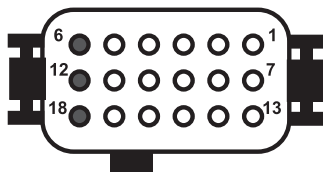
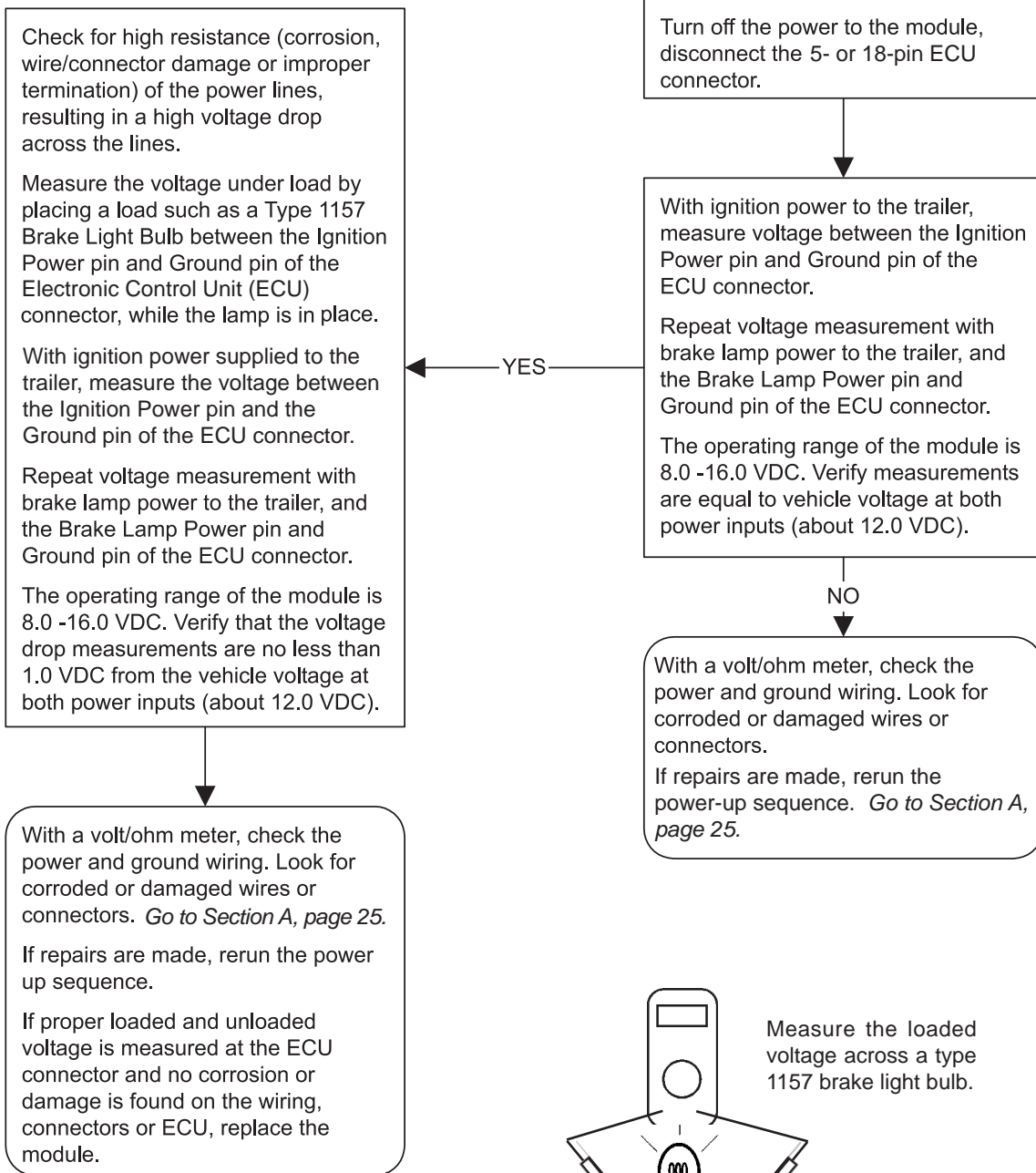

Looking into Premium Bendix® TABS-6™ Module Wire Harness, ECU Connector Measure:
Pin 6 (Ignition Power) to Pin 18 (ground) and
Pin 12 (Brake Light Power) to Pin 18 (ground)

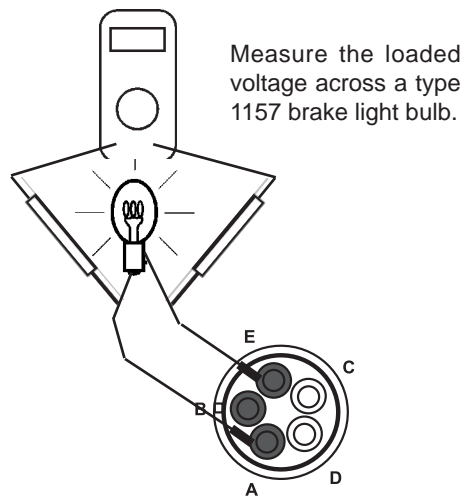

Looking into Standard Bendix TABS-6 Module Wire Harness, ECU Connector Measure:
Pin B (Ignition Power) to Pin E (ground) and
Pin A (Brake Light Power) to Pin E (ground)

SECTION G: TROUBLESHOOTING BENDIX® WS-24™ WHEEL SPEED SENSOR (WSS) DIAGNOSTIC TROUBLE CODES (DTCs)

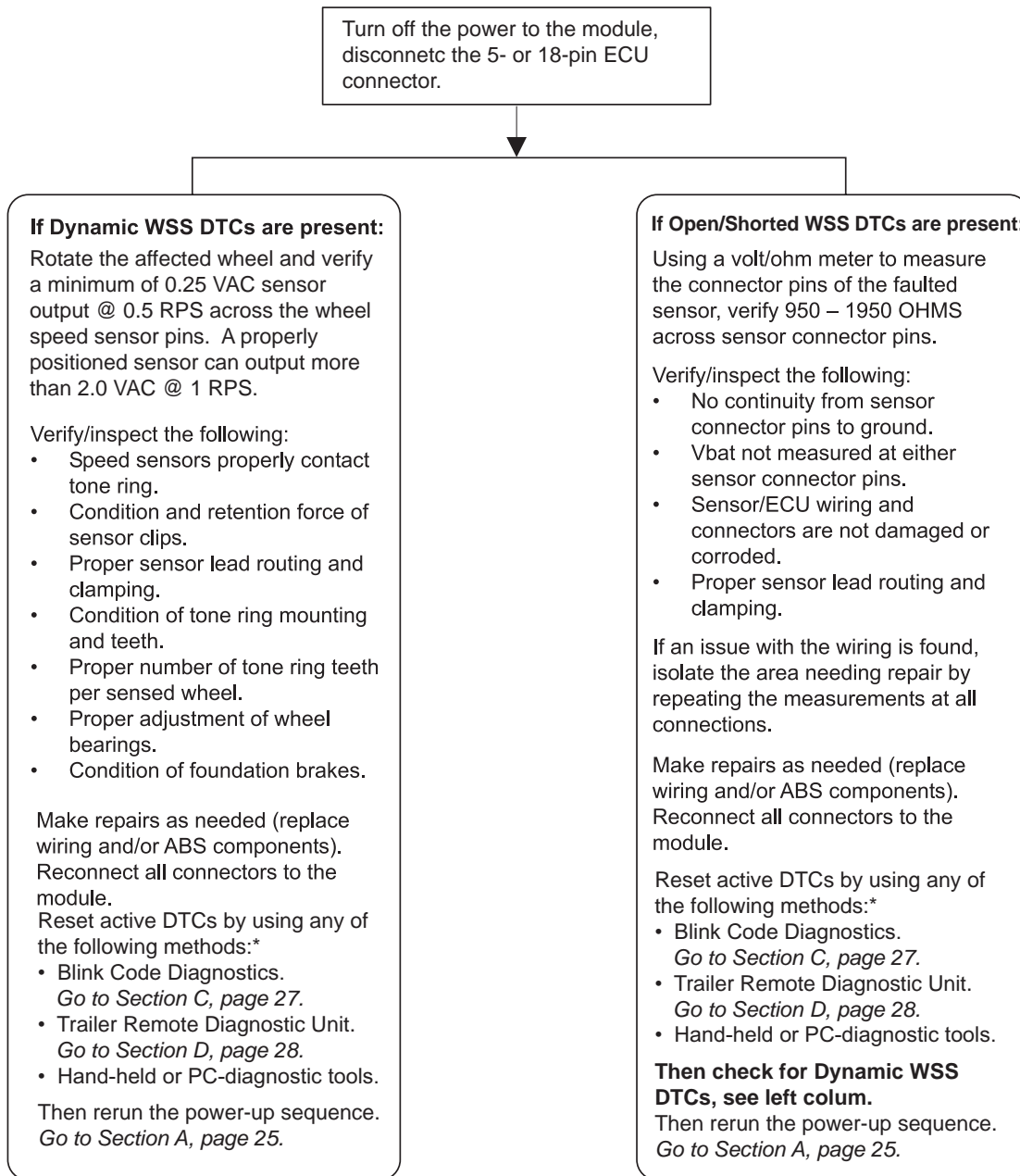

*If the technician does not reset the active DTCs, they will remain until both the vehicle's power is cycled and a valid wheel speed signal is detected by the Electronic Control Unit (ECU). **Note: Both Static and Open/Shorted WSS DTCs may be present.**

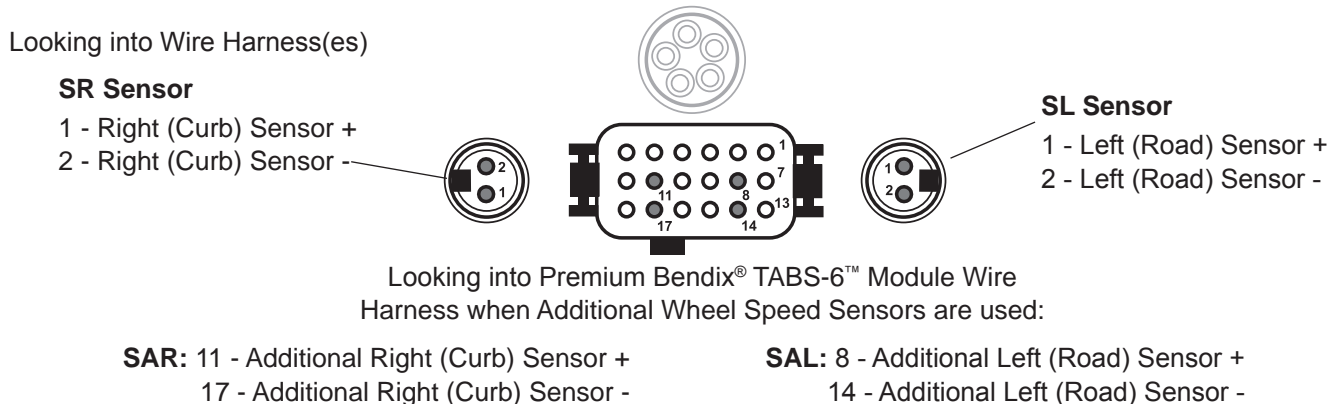

SECTION H: TROUBLESHOOTING THE MODULATOR RELAY VALVES

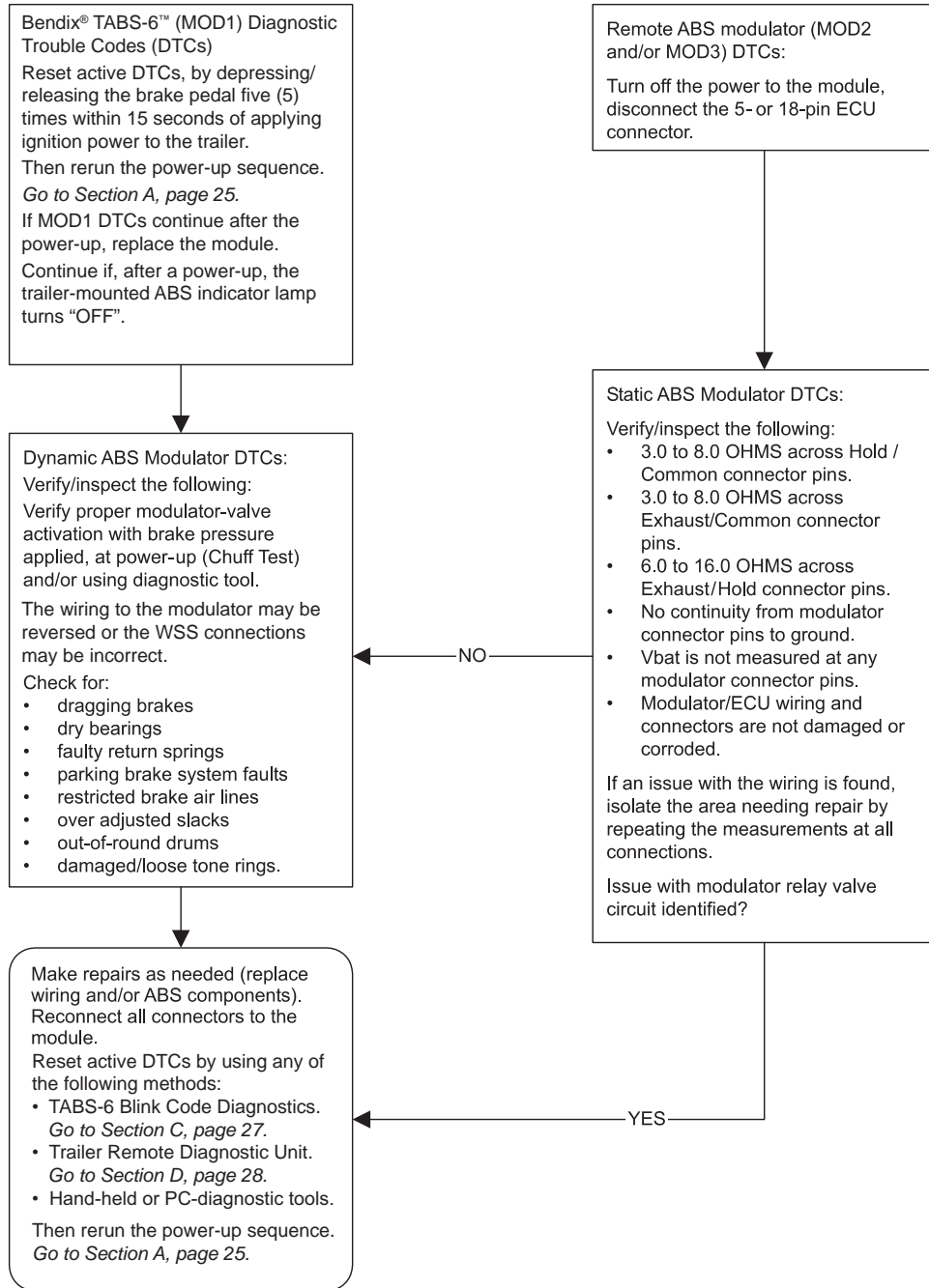

Premium Bendix® TABS-6™ Module Wire Harness for Bendix® BR9235™ Modulator Valve Connector

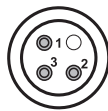

Looking into Modulator

Connector Pins:

- Pin 1 (Release)
- Pin 2 (Common)
- Pin 3 (Hold)

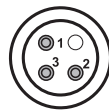

(Optional)

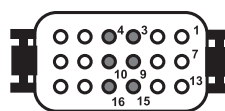

Looking into Wire Harness

Connector:

- | | |
|-----------------------|------------------------|
| Pin 9 is MOD2 release | Pin 10 is MOD3 release |
| Pin 3 is MOD2 Common | Pin 4 is MOD3 Common |
| Pin 15 is MOD2 Hold | Pin 16 is MOD3 Hold |

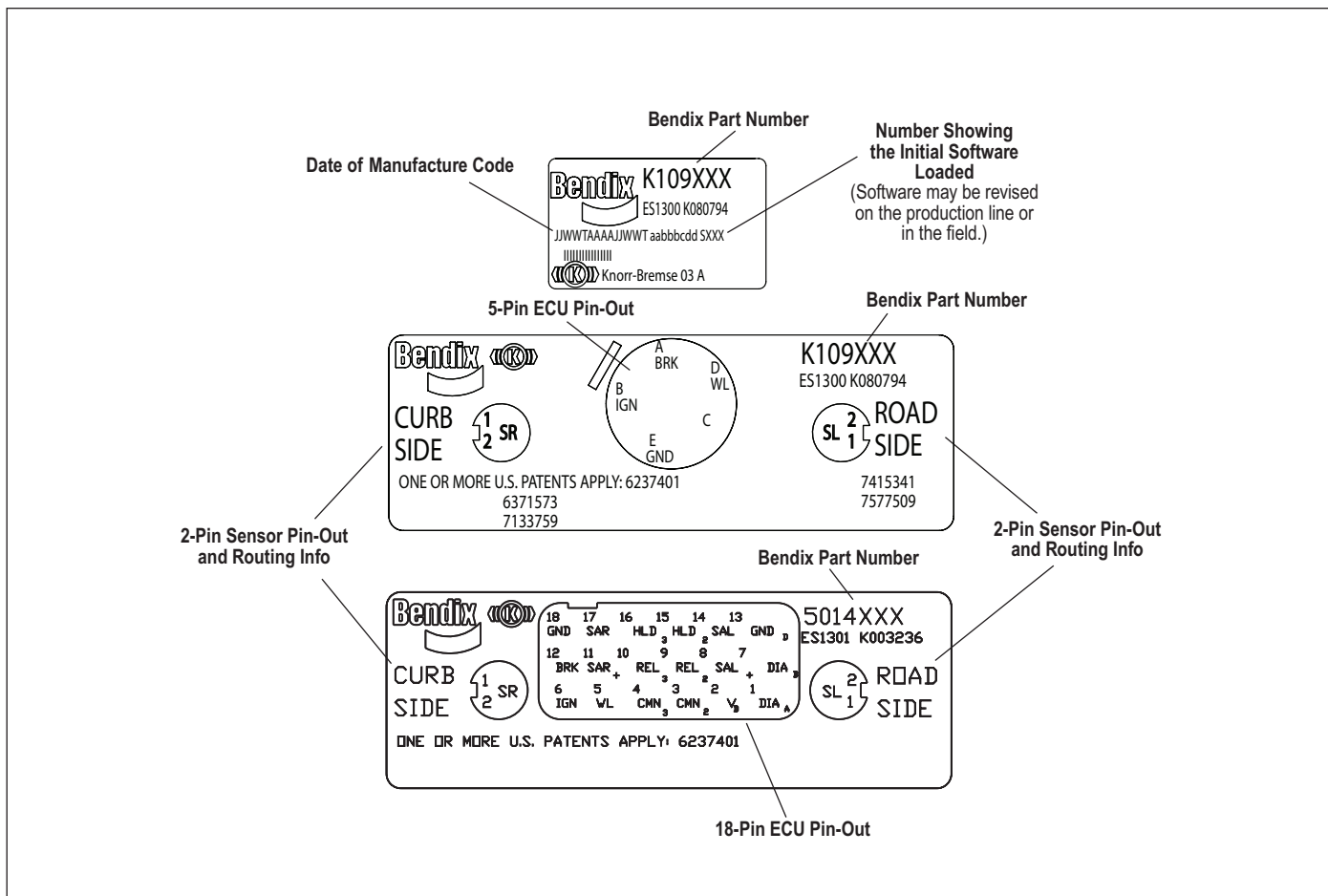

FIGURE 17 - LABEL INFORMATION

ECU Part Number Label

The external part number label is located on the relay valve portion of the module. Label shown above is located under the removable cover of the Bendix® TABS-6™ module. If the part number label is not readable or is painted over, the ECU part number and revision can be read using a diagnostic tool. The number of the initial software loaded on the ECU is also indicated.

The module part number, and pin-out information is shown on the label beneath the removable cover.

Software Revision Level

The current software revision number can be read using a diagnostic tool.

Document Revision Level

For additional information on Bendix products and to ensure you have the latest version of the Service Data Sheet, please visit www.bendix.com.

- For the Bendix® TABS-6™ Standard and Premium Trailer ABS module, use this document;
- For the Bendix® Single-Channel TABS-6™ Advanced module, use SD-13-47671;
- For the Bendix® TABS 6™ Advanced Multi-Channel Trailer ABS module, SD-13-47672; and
- For the Bendix® WS-24™ AntiLock Wheel Speed Sensor, use SD-13-4860.

NOTES

NOTES



Log-on and Learn from the Best

On-line training that's available when you are –24/7/365.

Visit www.brake-school.com.