



Bendix® ADB22X® & ADB22X®-LT Air Disc Brake Troubleshooting Guide

A troubleshooting flowchart is provided in Section 3 of the *Bendix® ADB22X® Service Data sheet (SD-23-7541)* and should serve as the process used for issue investigation. The points below provide a quick reference for common component questions, but is not a replacement for the detailed procedures contained in the Service Data sheet. Before starting work, refer to the General Safety Guidelines on page 2.

Component (Item / Condition)		Investigation	Specs	Procedure from SD-23-7541	What To Replace	
Consumable Items: These are considered to be normal wear items and should be repaired as part of regular preventive maintenance.						
Disc Brake Pads	A	Worn	Measure the thickness of the remaining friction material.	Pads must be replaced when they reach 0.080 in. (2 mm) of friction material. - NA CVSA Out of Service limit = .0625 in. (1.6 mm) - US DOT min. pad thickness = .125 in. (3.2 mm) - CA CCMTA min. pad thickness = .080 in. (2 mm)	Section 4.3	Replace the pads on both sides of the worn axle.
	B	Uneven wear on single pad	Measure the thickness of the total pad in at least (two) 2 places at the top and two (2) places at the bottom, at least 1/2 in. from the edge.	The average difference of top vs. bottom or left vs. right should be no greater than 0.080 in. (2 mm).	Section 4.3.2	Replace the pads on both sides of the worn axle and replace the guide pins as needed.
	C	Uneven wear on inboard vs. outboard	Measure the pad thickness as described for Item B above, but also check guide pin wear and slide-ability.	Average difference inboard to outboard should be no greater than 0.138 in. (3.5 mm).	Section 4.3.3	
	D	Surface damage	Inspect for minor chips near the edge and cracks on the face (permitted) vs. major sections damaged or missing.	<i>See Figure 24.</i>	Section 4.3.3	Replace the pads on both sides of the worn axle.
Boots & Seals	E	Tears & cuts	Inspect the tappet and guide pin boots for cuts, cracks, and tears.	Any damage must be repaired.	Sections 4.5.4 & 4.6.2	Replace the damaged boots and replace the resultant internal corroded guide pins as needed.
	F	Melting	Inspect as Item E above, but also check the running clearance before removing the brake pads.	Any damage must be repaired.	Sections 2.2 & 4.6.1	
Guide Pins	G	Binding	With the pads removed, the caliper should move freely by hand. Re-torque the carrier to anchor plate bolts per the OE spec and procedure, if binding.	<i>See Figure 26 (slide) and Table 4 (torque).</i>	Sections 4.5.1 & 5.3	Replace worn guide pins as needed. If guidance system binding still occurs, replace caliper/carrier assembly. Replace anchor plate if new caliper/carrier assembly does not resolve issue.
	H	Excessive play	Feel for excessive play between the caliper and the carrier.	<i>See Figure 27.</i>	Section 4.5.2	Replace the worn guide pins as needed.
Rotors	I	Worn	Measure the rotor thickness with a long jaw caliper.	Thickness must be greater than 1.46 in. (37 mm).	Section 4.4	Refer to the OEM recommendations for non-Bendix® rotors. For Bendix rotors, replace the rotors on both sides of the axle.
	J	Surface damage	Minor cracks and grooves are acceptable, but check for cracks over the inside and outside edges.	<i>See Figure 25 for surface details.</i>		Refer to the OEM recommendations for non-Bendix rotors. For Bendix rotors only, replace the rotor that is damaged.
Non-Serviceable: These are non-serviceable items and pending warranty terms; these issues may be covered under warranty.						
Calipers	K	Adjuster not rotating	If the second shear adapter breaks while turning the 10 mm box-end wrench counterclockwise, the adjuster is seized.	Adjuster must turn in both directions with a hand wrench.	Section 4.2	Caliper only must be replaced with malfunctioning adjuster.
	L	Adjuster too tight, dragging brake	With the brakes released, check the running clearance between the tappet and the inboard pad.	The gap should be between 0.024 in. (0.6 mm) and 0.047 in. (1.2 mm).	Section 4.1	Install and torque the replacement caliper per section 5.3.7.

Bendix® ADB22X® & ADB22X®-LT Troubleshooting Guide

Disc Brake Pads

A) Worn Pads

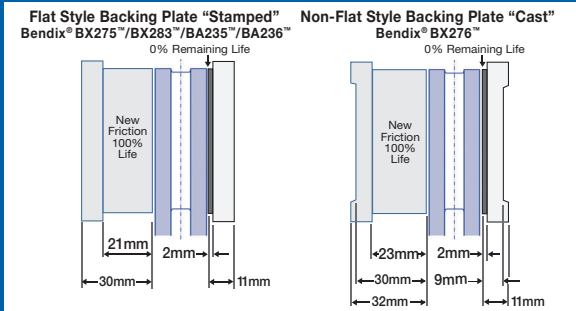

B) Uneven Wear on Single Pad

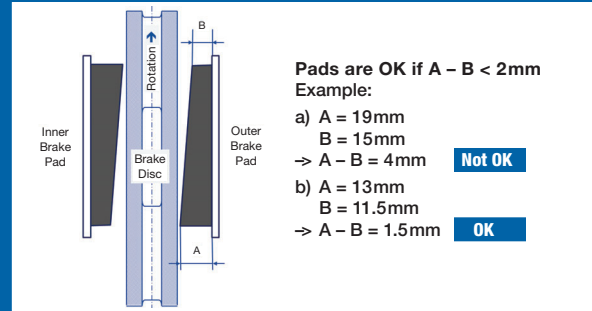

C) Uneven Wear on Inboard vs. Outboard

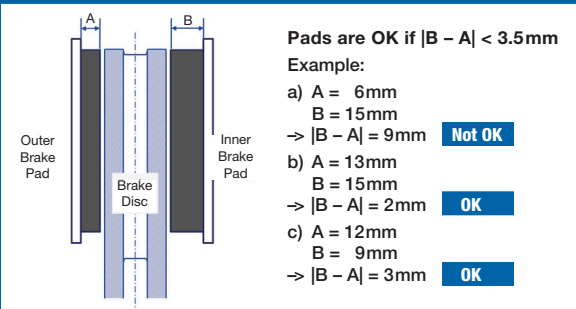

D) Pad Surface Damage



Boots & Seals

E) Tears and Cuts



F) Melting



Rotors

I) Worn Rotors

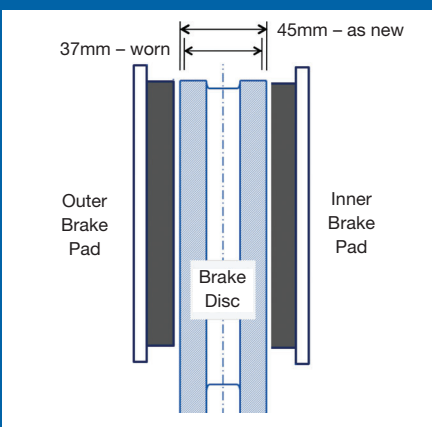

J) Surface Damage

